

GC-IMS-SILOX



USER MANUAL



**G.A.S. Gesellschaft für
analytische Sensorsysteme mbH**

GC-IMS-SILOX - User Manual

Version 1.4.6, March 2025

All data, texts, designs, images and other elements used in this user manual are protected by copyright law. Any infringement may be subject to legal action.

Passing it on to third parties and producing copies of any kind or form - on the whole or in parts - is not permitted without written agreement of G.A.S. Any infringement may be subject to legal action.

G.A.S. reserves the right to realize technical changes to the product without explicitly mentioning them.

CE-Marking according to:

International Standard EN ISO 17050-1:2004

European Union Low Voltage Directive 2006/95/EC

European Union Electromagnetic Compatibility Directive 2004/108/EC

© Copyright 2015-2025

**G.A.S. Gesellschaft für analytische Sensorsysteme mbH
44227 Dortmund - Germany**

All Rights Reserved.

Table of Content

1	Preface.....	6
1.1	Symbols Used in this User Manual	6
1.2	Notation for Describing Dialogs and Elements in Dialogs	7
1.3	Liability and Guarantee	7
1.4	Return and Disposal	8
1.5	Packing.....	8
1.6	Transport	9
1.7	Software Updates.....	9
1.8	Contacting G.A.S.	9
2	Safety	11
2.1	Intended Usage Only	11
2.2	Responsibilities of the Operator.....	11
2.3	Ionization Source	12
2.4	Explosion Protection	12
2.5	Protection from High Voltage.....	13
3	Scope of Supply and Storage Conditions	14
3.1	Scope of Supply	14
3.2	Storage Conditions	15
4	Cleaning of the Housing and Maintenance	16
4.1	Cleaning of the Housing	16
4.2	Maintenance.....	16
5	Intended Use and Working Principle.....	17
5.1	Intended Use	17
5.2	Calculating Concentrations	17
5.3	Working Principle and Internal Gas Flow.....	19
6	Workflow: Physical Setup	22
6.1	Housing of the Device.....	22
6.2	Device Type/Serial Number Plate on the Rear Side	24
6.3	Unpacking, Placement and Connections	25
6.4	Special version GC-IMS SILOX Open frame	30
6.4.1	Connections of GC-IMS SILOX open frame device	31







7	Workflow: Initial Operation / Cleaning	40
7.1	Using the Cleaning Mode	40
7.2	Workflow	40
8	Sampling Methods	44
9	Device Parameters During Measurements and Standby	46
9.1	Introduction	46
9.2	Values	46
10	Workflow: Single Manual Measurement	47
10.1	Introduction	47
10.2	Workflow	48
11	Workflow: Manual Calibration	52
11.1	Introduction	52
11.2	Workflow	52
12	Workflow: Running Automatic Measurements.....	56
12.1	Introduction to the Interval Mode	56
12.2	Workflow	57
13	Workflow: Current Loop Setup	63
13.1	Introduction	63
13.2	Electrical Interface	64
13.3	Configuring the Current Loop.....	64
14	Workflow: Tag Lists	67
14.1	Introduction	67
14.2	Creating and Editing Tag Lists.....	68
14.3	Usage.....	71
14.4	Exporting Tag Lists	73
14.5	Importing Tag Lists.....	76
15	Workflow: File Transfer Setup	80
15.1	Overview.....	80
15.2	Connecting to a Server in a LAN	82
16	Workflow: PDF Reports - Setup and Usage.....	89
16.1	Introduction	89
16.2	Workflow	91
17	Workflow: Firmware Upgrade	95
17.1	Introduction	95

17.2	Workflow.....	96
18	Workflow: Password Protection	99
18.1	Introduction	99
18.2	Workflow.....	100
19	Graphical User Interface	102
19.1	Introduction	102
19.2	Start Page.....	103
19.2.1	Overview	103
19.2.2	Results View	105
19.2.3	Scope View.....	106
19.3	MEA Mode Start Dialog.....	107
19.4	Calibration Mode Start Dialog	108
19.5	Substances and the Substance Calibration Dialog	109
19.6	Interval Mode Start Dialog	111
19.7	Date and Time Input Dialogs.....	113
19.8	Status Bar.....	115
19.9	Substances Page	117
19.10	System Page	118
19.10.1	System Page Info Tab.....	119
19.10.2	System Page Plan Tab	120
19.10.3	System Page Settings Tab.....	121
19.10.4	System Page Transfer Tab	126
19.10.5	The System Page Modes Tab	128
19.11	Current Loop Settings Dialog	129
19.12	Log Messages Dialog.....	130
19.13	IP Address Input Dialog	131
19.14	Text Input Dialog	132
19.15	Number Input Dialog	132
20	Tag Lists File Formats.....	134
20.1	Overview.....	134
20.2	CSV Format Specification.....	135
20.3	JSON Format Specification	135
21	Technical Specifications	137
21.1	Measurement Ranges.....	137
21.2	Device	138

21.3	Current Loop Interface	140
21.4	Consumables	140
21.5	Ionization Source Specifications	141
21.6	Modbus TCP Specification	142
22	Calculating of silicon 'Total Si' and silica 'Total SiO ₂ ' in GC-IMS-SILOX ...	151
	Addendum for GAS Internal use	156
	LABMODE - Short introduction	156

1 Preface

1.1 Symbols Used in this User Manual

Symbol	Description
	Danger This symbol marks paragraphs that describe situations that can potentially damage the device.
	Danger - Radioactive Radiation This symbol marks paragraphs that describe potential dangers and damage due to exposure to radioactive radiation.
	Danger - Explosive Substances This symbol marks paragraphs that describe potential dangers and damage due to explosions.
	Danger - High Voltage This symbol marks paragraphs that describe potential dangers to life and health due to electric current.
	Danger - Hot Surface This symbol marks paragraphs that describe situations in which surface parts of the device can heat up to a point where touching it or bringing objects close to it may be hazardous.
	Important This symbol marks paragraphs that describe important instructions or information that may prevent the operator from making common mistakes.

1.2 Notation for Describing Dialogs and Elements in Dialogs

Example:

System > **Connections** > **LAN File Transfer** > **Settings...** > **Test Connection**

Describe the logical path for arriving in a particular dialog or at an element in a dialog. In this example the path starts with the **System** page. On that page the **Connections** page must be selected. On that page in the **LAN File Transfer** row the button **Settings...** must be selected and in that dialog the button **Test Connection** must be selected.

Example:

Gas Out, **S-Free**

Casing socket names, choice menu elements etc. are marked in this way.

1.3 Liability and Guarantee

This user manual describes the safe and proper handling of the device.



Usage other than described in this manual may damage the device and/or harm persons involved.

Do not use the device for other purposes. Damages due to misuse are not covered by the guarantee. Such damage claims will be rejected.

This user manual should be available to all personnel operating the device.

Follow the safety instructions in this manual and the national and/or local rules and general safety regulations regarding the prevention of accidents at all times.

Before starting to operate the device read the manual completely and thoroughly. Make sure that all personnel operating the device understand the instructions described.

G.A.S. does not assume any liability for damages resulting from neglect or ignorance of the instructions in this manual or provided in other ways by G.A.S.

The graphics in this user manual are schematic and may differ from the actual conditions. The firmware and PC software screen shots in this user manual may slightly differ from the actual conditions.

The actual scope of supply might differ due to customization. For further information please contact G.A.S.

1.4 Return and Disposal

For an appropriate disposal, the device and the associated equipment must be returned to G.A.S. or to a third party authorized by G.A.S.

1.5 Packing

If no return agreement regarding the packing was agreed upon dispose the packaging material always in an environmentally friendly way and according to valid local regulations. If necessary, ask a recycling company.

1.6 Transport

To prevent damages to the equipment it should be moved only in the provided carrying case.



Protective caps should be put on gas sockets in case the device is stored or transported.

1.7 Software Updates

To receive information on available updates for the components of the system please contact G.A.S. Gesellschaft für analytische Sensorsysteme mbH. If there are any updates customers will be contacted by G.A.S. Gesellschaft für analytische Sensorsysteme mbH as soon as the updates are available. Users will be provided with information about the changes and instructions for executing the updates.

1.8 Contacting G.A.S.

For questions concerning G.A.S. products a customer service is available:

G.A.S. Gesellschaft für analytische Sensorsysteme mbH

Otto-Hahn-Straße 15

44227 Dortmund

Germany

Phone: +49 (0) 231 / 97 42 - 65 50

Fax: +49 (0) 231 / 97 42 - 65 55

support@gas-dortmund.de

The telephone hotline is available from Monday to Friday from 9:00 to 16:00 hours. In urgent cases or if you use fax or email please provide a telephone number for callbacks.

2 Safety

2.1 Intended Usage Only



Usage other than described in this manual may damage the device and/or harm persons involved. Do not use the device for other purposes. Damages due to misuse are not covered by the guarantee. Such damage claims will be rejected.

2.2 Responsibilities of the Operator

The device should only be operated in a perfect technical condition. Before putting the device into operation the condition of the device and its equipment must be checked. The information and instructions provided in this manual must be followed at all times.

Besides the instructions provided in this manual the local rules for the prevention of accidents, general safety regulations - valid for the area of application of the device - as well as the valid environment protection regulations must be considered and respected.

Responsibilities of the involved persons regarding installation, operation, maintenance and cleaning must be made clear.

Only authorized and trained personnel may operate the equipment. The operators must know potential dangers and how to avoid them and should be

regularly trained on safety procedures and environmental protection regulations.

Persons under the influence of drugs or alcohol must not operate the device.

Any changes to the equipment, which may endanger the operators must be reported immediately to the operators and any person handling it.

2.3 Ionization Source

The device contains a Tritium radioactive ionization source of 300 MBq (Below exemption limit according to EURATOM Directive 96/26).



Do not open the device! Do not try to repair any internal malfunctions of the device! Internal malfunction recovery, repairs and any maintenance work may only be carried out by G.A.S. or by personnel authorized by G.A.S.

2.4 Explosion Protection

The device is not certified for deployment in areas with explosive gas/air mixtures or other explosive substances.



Do not deploy the device in areas exposed to explosive substances or mixtures.

2.5 Protection from High Voltage



Exercise great care in handling current-carrying parts like the power supply cord. Do not get directly in touch with current-carrying parts. Do not open the housing. Do not use damaged parts.

3 Scope of Supply and Storage Conditions

3.1 Scope of Supply

Ensure that you have received the full scope of supply. If there is any part missing, please contact G.A.S. immediately.

Standard Scope of Supply
Device
Power Supply
Power Supply Cable
Gas tubes (6 x 2 m) with 3mm Swagelok Connectors
Drift Gas / Carrier Gas Adapter with 3mm Swagelok Connectors
Sample Gas Bypass Adapter with 3mm Swagelok Connectors
D-Sub Plug, Male, Wireable for Current Loop Connection
Moisture Trap
Device User Manuals
Software-CD with IMScontrol TFTP-Server
Document - Technical Approval Certificate
Document - Analytical Approval
Document - Declaration of Conformity
Document - Radiation Source Certificate

Optional Items
Large Moisture Trap
Transport Case
Notebook PC for direct file transfer

3.2 Storage Conditions



Check the storage conditions regularly

Storage Conditions
When not in use store the equipment in the supplied casing
Prevent unauthorized access
Do not store outside
Protect the equipment from moisture and dust
Put protective caps on all gas sockets of the device and the molecular sieve
Avoid mechanical vibrations
Do not expose the equipment to aggressive substances
Protect the equipment from direct sun light
Storage temperature: 15 to 40 °C
Relative Air Humidity: Max 60 %

4 Cleaning of the Housing and Maintenance

4.1 Cleaning of the Housing

Regular use of the device requires periodic cleaning.



Clean the outside of the device casing only with a dry or slightly damp cloth. Do not use cleaning agents that contain solvents, acids or bases.

4.2 Maintenance

Natural aging and the wear of certain components of the equipment require regular cleaning and maintenance.

The recommended maintenance interval is 12 months.



Maintenance of the equipment must be carried out by G.A.S. or personnel authorized by G.A.S.



Please contact G.A.S. 6-8 weeks in advance to optimize the turn-around time!

5 Intended Use and Working Principle

5.1 Intended Use

The intended use of the GC-IMS-SILOX device is the measurement of siloxane concentrations in biogas from landfills, digestors and sewage.

5.2 Calculating Concentrations

The device can measure siloxanes within the following concentration ranges:

Substance	Measurement Range
Siloxane - L2	Up to 10 mg/m ³ - Standard 0.03 to 2.0 mg/m ³
Siloxane - D3	Up to 10 mg/m ³ - Standard 0.03 to 2.0 mg/m ³
Siloxane - L3	Up to 10 mg/m ³ - Standard 0.03 to 2.0 mg/m ³
Siloxane - D4	Up to 10 mg/m ³ - Standard 0.03 to 2.0 mg/m ³
Siloxane - L4	Up to 10 mg/m ³ - Standard 0.03 to 2.0 mg/m ³
Siloxane - D5	Up to 10 mg/m ³ - Standard 0.03 to 2.0 mg/m ³
Siloxane - L5	Up to 10 mg/m ³ - Standard 0.03 to 2.0 mg/m ³
TMSOL	Up to 10 mg/m ³ - Standard 0.03 to 2.0 mg/m ³



The actual ranges may differ and may be customized to specific requirements. They are displayed in the Substance Calibration Dialog.

→ 19.5 Substances and the Substance Calibration Dialog

When the calculated concentration value exceeds the respective maximum value **MaxVal** it is displayed as “> MaxVal”.

When the calculated concentration value is below the respective minimum value it is displayed as “n.d.” standing for “not detected”.



The concentration value of compound substances like **Total Siloxanes** is derived from base substances (**L2**, **L3**, ...). When one or more base substance concentrations exceed their concentration ranges the value for the compound substance is derived from the limits.

When for all base substances (**L2**, **L3**, ...) a “n.d.” is calculated the result for the compound substances is “n.d.” as well.

22 Calculating of silicon 'Total Si' and silica 'Total SiO₂' in GC-IMS-SILOX

5.3 Working Principle and Internal Gas Flow

The schematics below show the main elements of the gas flow system of the device. The system consists of a gas chromatograph (GC) using a capillary column coupled to an ion mobility spectrometer (IMS).

For displaying the plan on the device see 19.10.2 System Page Plan

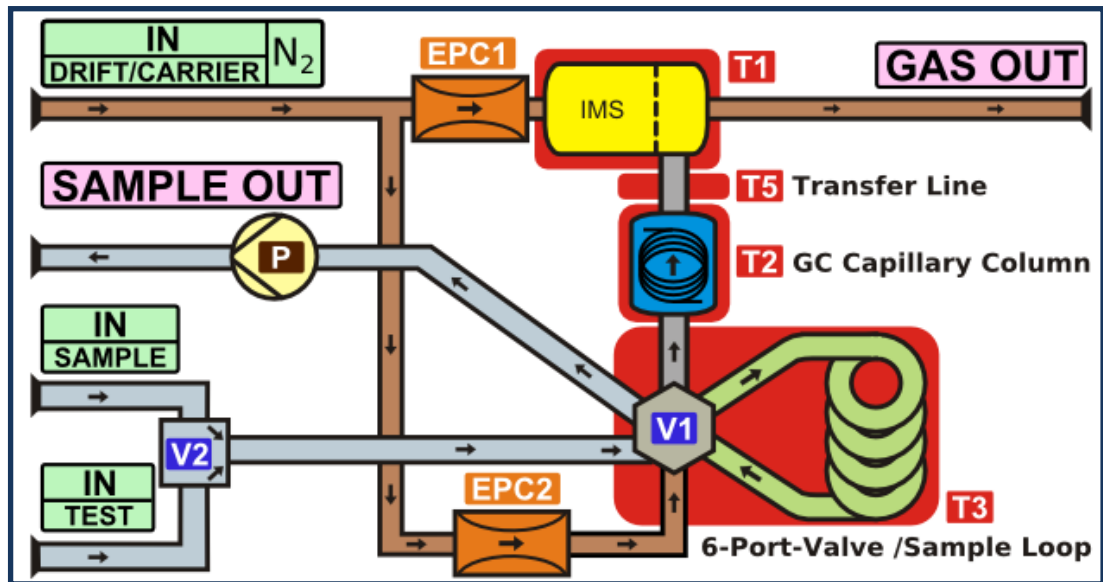

Figure 1: Device Plan

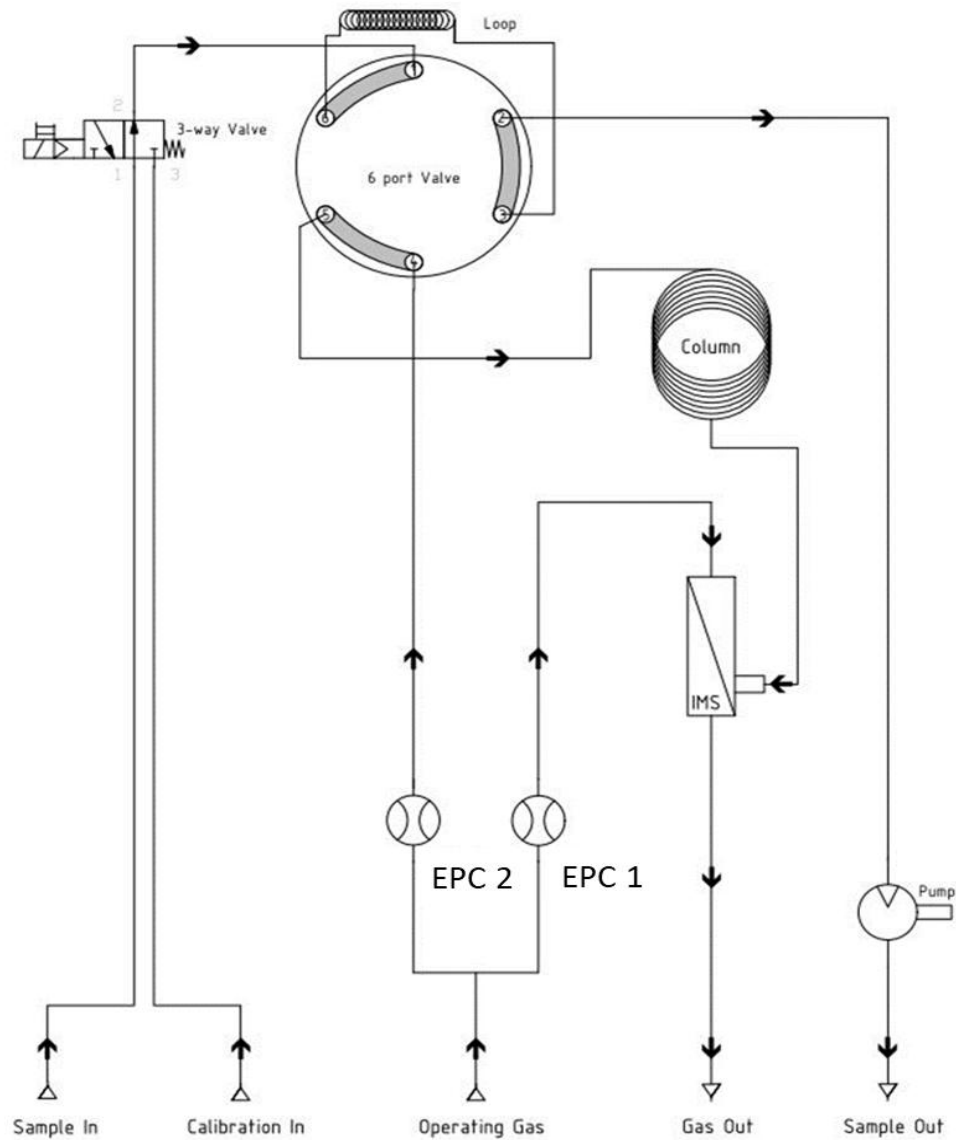

Figure 2: Flow-chart

The drift gas flow to the **IMS** sensor is controlled by the electronic pressure control unit **EPC1**. The carrier gas flow to the column is controlled by **EPC2**. Carrier gas and drift gas leave the device through the **Gas Out** outlet at the rear side of the device, which should be connected to an appropriate waste gas ventilation system. **IMS** sensor, **GC** column and **6-Port-Valve** with sample loop are heated (**T1**, **T2** and **T3** respectively). The transfer line between **GC** and **IMS** sensor is heated by **T5**.

The sample gas or test gas is sucked in by pump **P** via **Samplegas In** and **Testgas In** at the rear side of the housing from the bypassing gas.



The minimum bypass flow is 200 ml/min.

The sample gas or test gas is carried via the **6-Port-Valve** to the gas chromatographic capillary column **GC** from where it elutes into the ion mobility spectrometer **IMS**.



The overpressure of the N₂ drift gas and carrier gas at the inlet must not exceed 6 bar (600 kPa).

In the default position of the **6-Port-Valve** the carrier gas (N₂) permanently flushes the gas chromatographic capillary column **GC**. When a measurement is started the sample gas flows through the loop controlled by **P**. In this position the sample gas from the **Sample In** socket or from the **Testgas In** socket is directly routed to the **Sample Out** socket.

When the **6-Port-Valve** switches to the inject position the sample in the loop is flushed into the column. The carrier gas now transports the sample through the column where the substances in the sample are separated by time. The eluting substances are transported into the ionization region of the **IMS** and leave the system via the **Gas Out** socket.

6 Workflow: Physical Setup

6.1 Housing of the Device

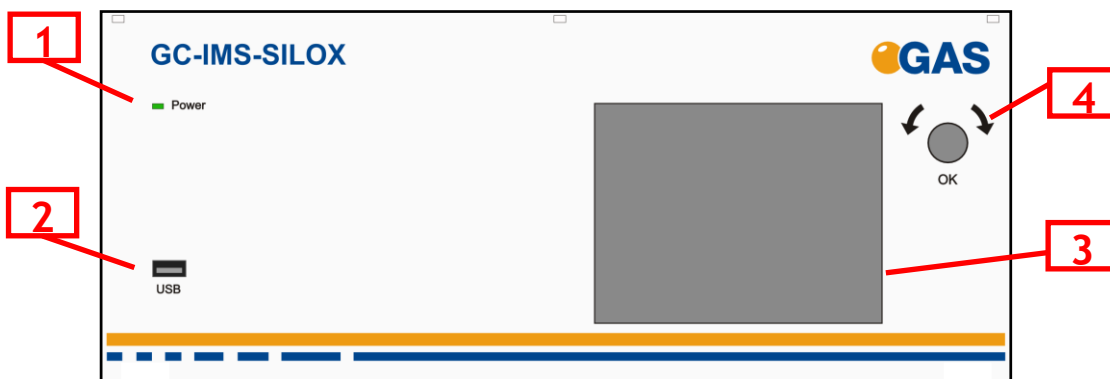

Figure 3: Front of the Housing

Element	Description
1 Power LED	Indicates whether or not the device is connected to a power supply and switched on.
2 USB Socket	USB socket for connecting external USB storage devices. These volumes can be used for exporting measurement files, for importing calibrations, for upgrading the device firmware and for saving or loading system settings.
3 Touchscreen Display	Displays the graphical user interface and allows the control of the device by touchscreen.
4 Pushable Rotary Knob	Input control for cycling through and activating the control elements of the graphical user interface.

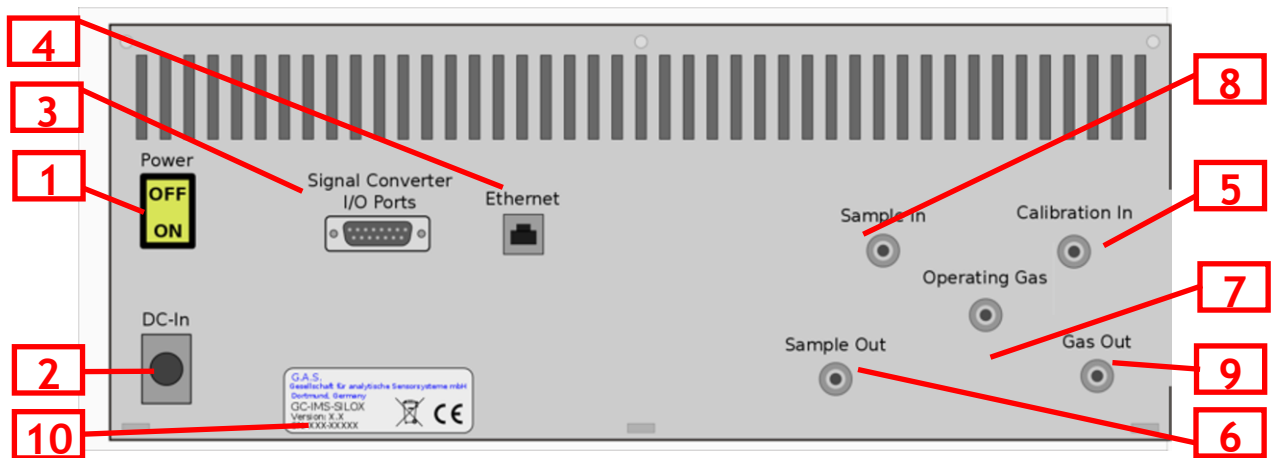

Figure 4: Rear of the Housing

Element	Description
1 Power Switch	Switches the device on or off.
2 DC-In Socket	24V XLR-Connector for connecting the device power supply.
3 Signal Converter I/O Port Socket	Socket for connecting a PLC (Programmable Logic Controller) or other devices. Can be used for connecting a current loop to the device.
4 Ethernet Socket	Socket for connecting the device to a local area network (LAN) or directly to a computer.
5 Calibration In Inlet	3 mm Swagelok inlet plug for connecting the device to a calibration gas source.
6 Sample Out Outlet	3 mm Swagelok plug for connecting the device to a waste gas ventilation system.
7 Operating Gas Inlet	3 mm Swagelok inlet plug for connecting the device to a operation gas source.
8 Sample In Inlet	3 mm Swagelok inlet plug for connecting the device to a gas source to be analyzed.
9 Gas Out Outlet	3 mm Swagelok plug for connecting the device to a waste gas ventilation system.
10 Device Type/Serial Number Plate	Displays manufacturer identification, device type, serial number and version.

6.2 Device Type/Serial Number Plate on the Rear Side

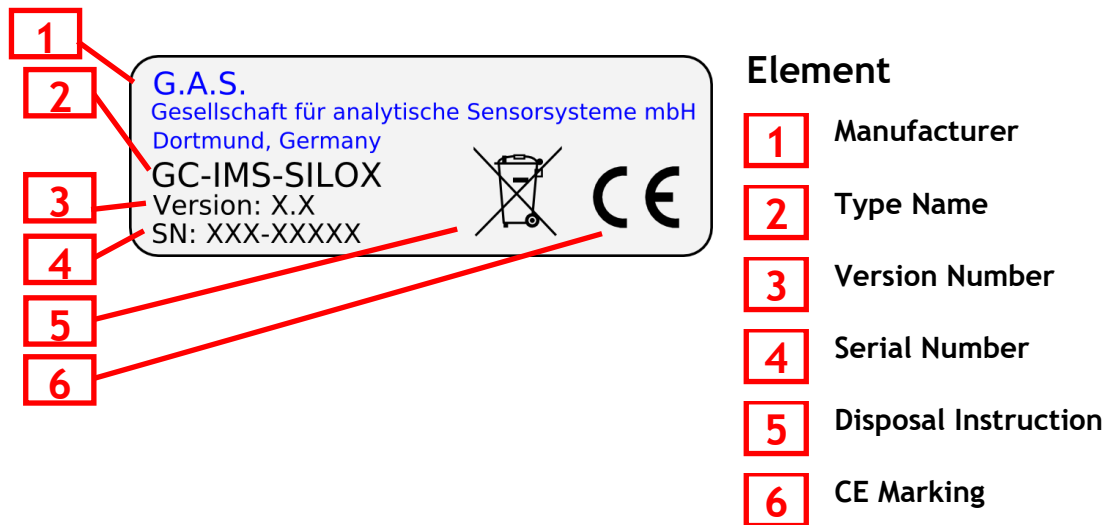

Figure 5: Device Type/Serial Number Plate

6.3 Unpacking, Placement and Connections

Workflow 1: Unpacking, Placement and Connections

1



Unpack the device. Remove the foam spacers. Remove the accessories boxes. Lift the device from the transport box.



Do not deploy the device in areas exposed to explosive substances or mixtures!

2

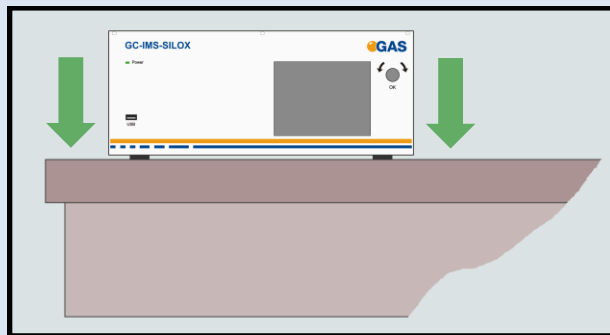

Place it on a robust table top of minimum footprint size of 60 cm x 70 cm. Ensure that there is enough working space at the rear side of the device.



Keep red protective cap on Calibration In socket in case no calibration gas is connected.

3

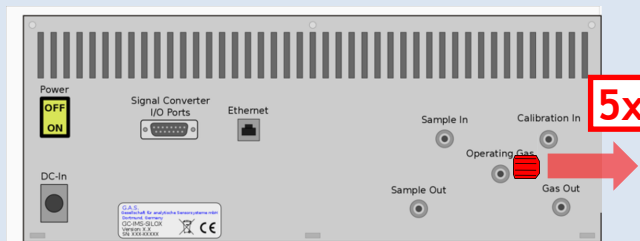

Remove red protective caps from gas sockets at rear of housing. Retain for future use.

4

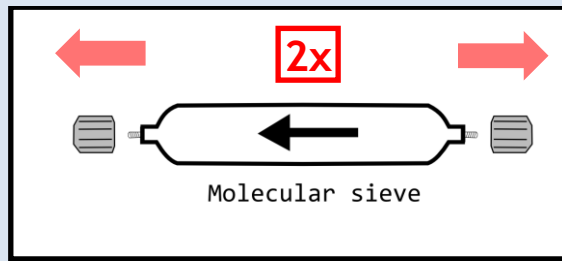

Remove protective caps from molecular sieve. Retain for future use.



Protective caps should be put on gas sockets in case the device is stored or transported.



Make sure that the power switch is set to **OFF** before connecting the power supply.

5

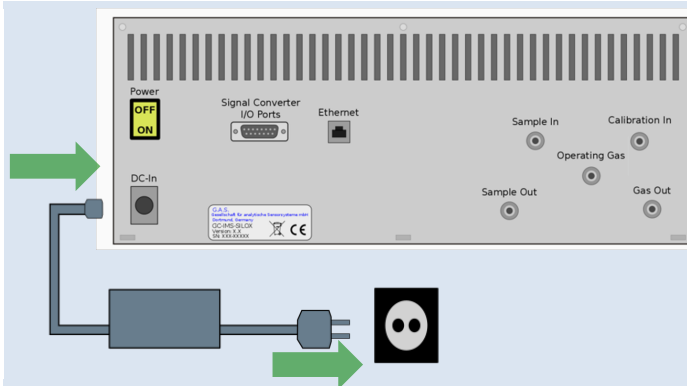

Connect device to power supply. Connect power supply to power socket.



Only use stainless steel pressure reducers, PTFE tubes with 3 mm outer diameter and 3 mm Swagelok connectors.

Screw on the Swagelok caps manually and fix them by screwing a further half-turn using a 12 mm open-end wrench.



Make sure that the nominal pressure of the nitrogen source does not fall below 10 bar (1000 kPa).



Do not introduce aggressive gases or liquids into the device.

6

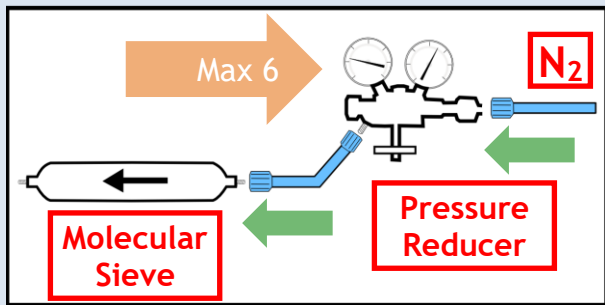

Connect nitrogen (Purity 5.0 or better) source to input of supplied molecular sieve.



Recommended pressure at socket **Operation Gas** is 3 bar - 4 bar (300 kPa - 400 kPa). 6 bar (600 kPa) must not be exceeded.

7

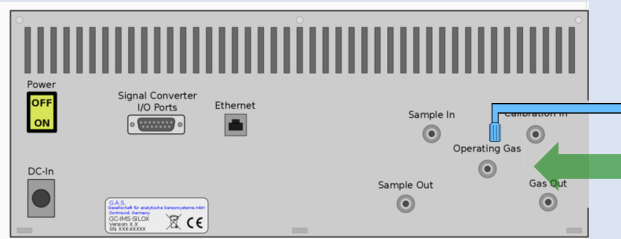

Connect molecular sieve outlet to gas socket **Operating Gas**.

8

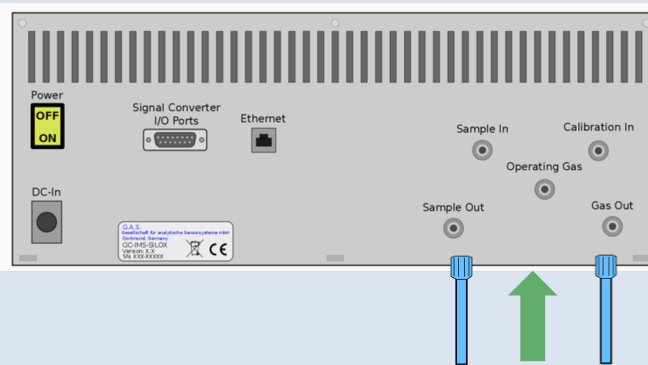

Separately connect sockets **Sample Out** and **Gas Out** to a **Non-sucking exhaust** or to **out-of-doors**.

9

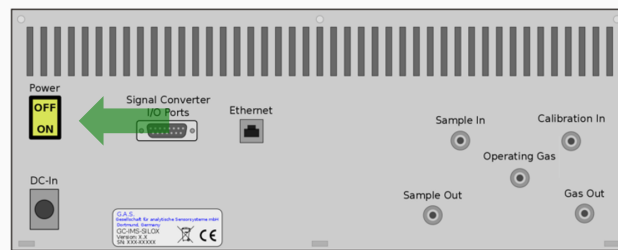

Switch on device.



Minimum bypass flow at sockets **Calibration In** and **Sample In**: 200 ml/min.



WARNING

Only connect gas to **Sample In** In or **Calibration In** with the delivered **bypass adapter**. Incorrect use can destroy the pump/device!

10

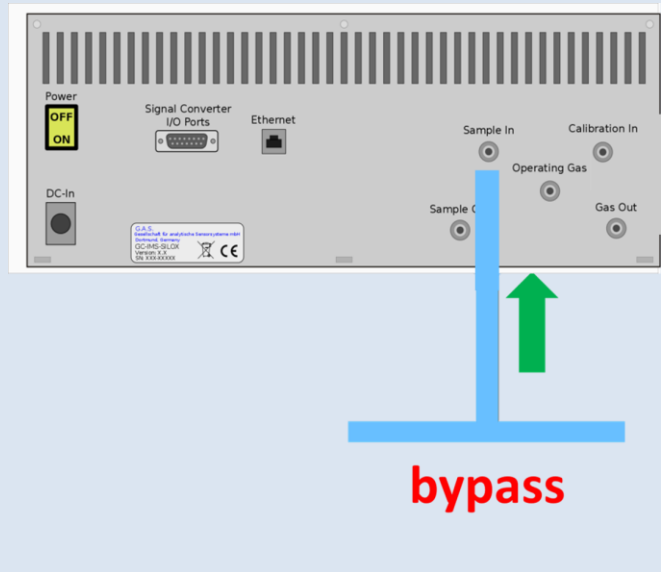

Connect sample gas source to socket **Sample In** with the delivered **bypass adapter**.

11

Option

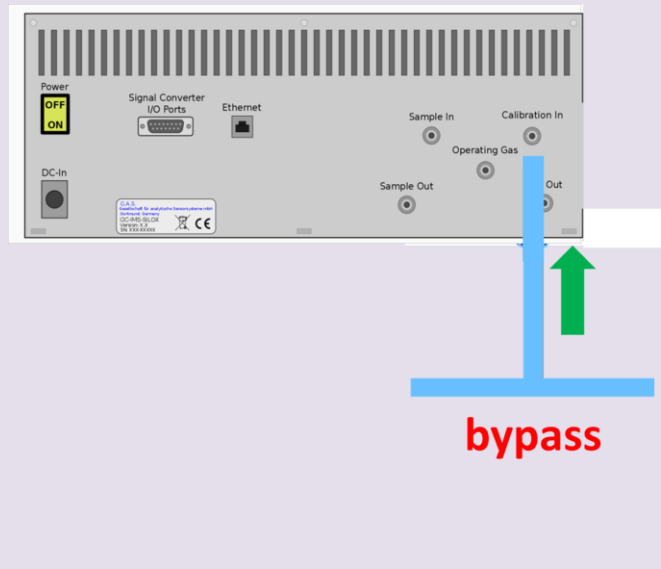

Connect calibration gas source to socket **Calibration In** with the delivered **bypass adapter** in case calibrations are desired.

12

Option

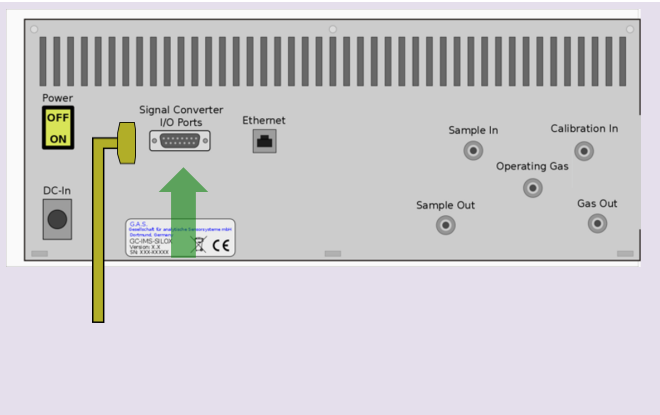

For the output of concentration values through the 0-20 mA current loop connect an appropriate cable to the **Signal Converter - I/O Ports** socket.

13

Option

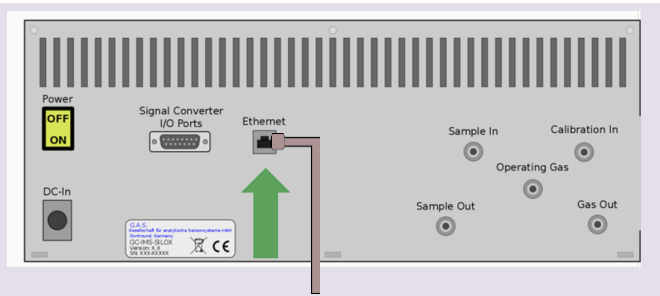

For file transfer via LAN: Connect the **Ethernet** socket with an appropriate Ethernet cable to a LAN.

6.4 Special version GC-IMS SILOX Open frame

The GC-IMS SILOX open frame version is intended for installation in a control cabinet. The gas connections and electrical connections are in other positions. The functionality of the system is identical to the standard version of the GC-IMS-SILOX.



Example



Installation in the control cabinet is carried out by the customer. The computer unit with screen must be connected via 5 connection cables.

6.4.1 Connections of GC-IMS SILOX open frame device

1

Gas connections of GC-IMS-SILOX open frame device

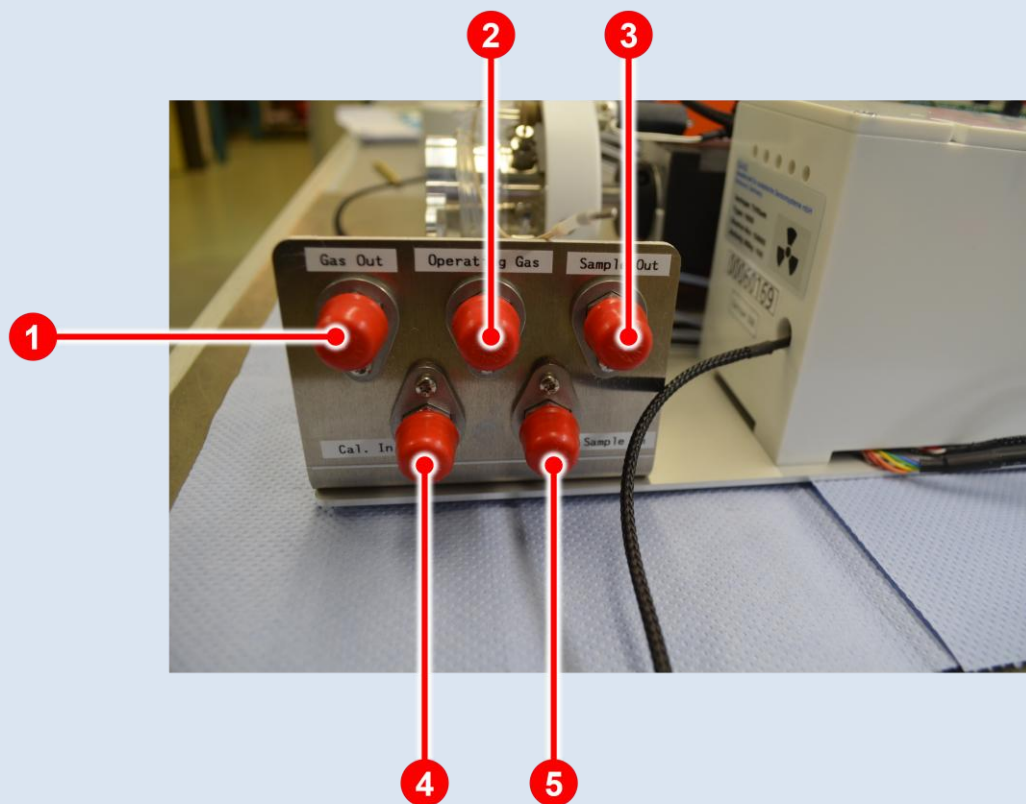

1	3 mm Swagelok Gas out connection
2	3 mm Swagelok Operation gas connection
3	3 mm Swagelok Sample out connection
4	3 mm Swagelok Calibration in connection
5	3 mm Swagelok Sample in connection

2

Power switch, Ethernet- and Signalconverter connections of GC-IMS-SILOX open frame device

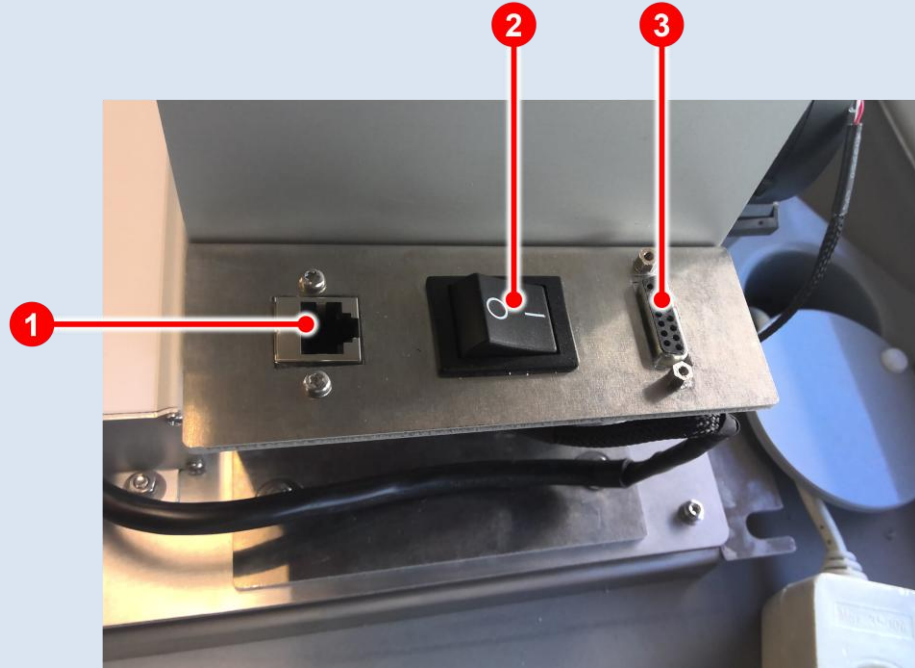

1	Ethernet Connection
2	Power switch
3	Signal Converter I/O Ports

3

Power supply with power supply cable of GC-IMS-SILOX open frame device

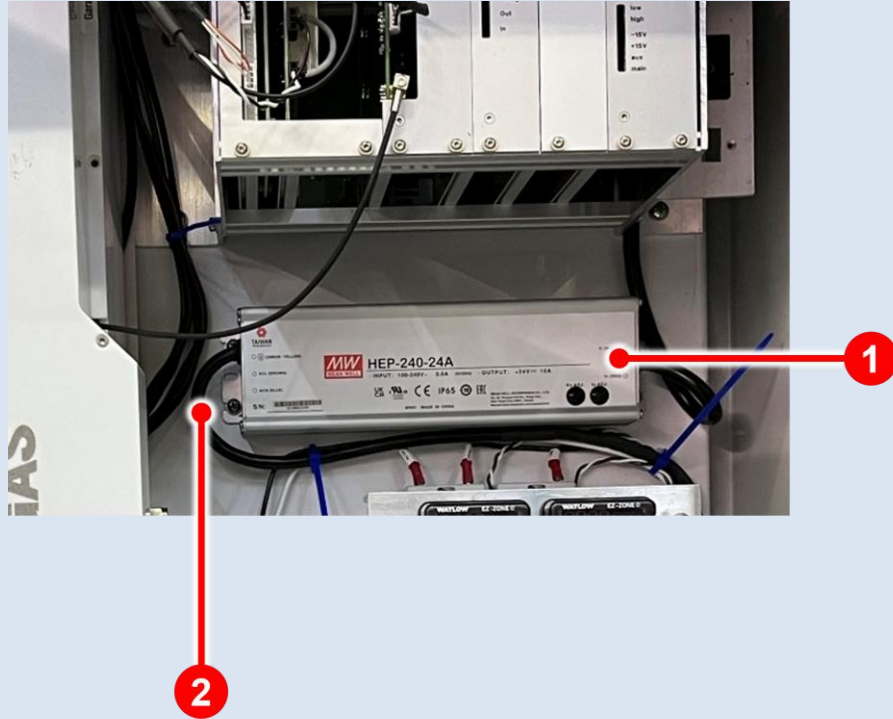

1	Power supply
2	Power supply cable

4

Connections for the computer unit of GC-IMS-SILOX open frame device

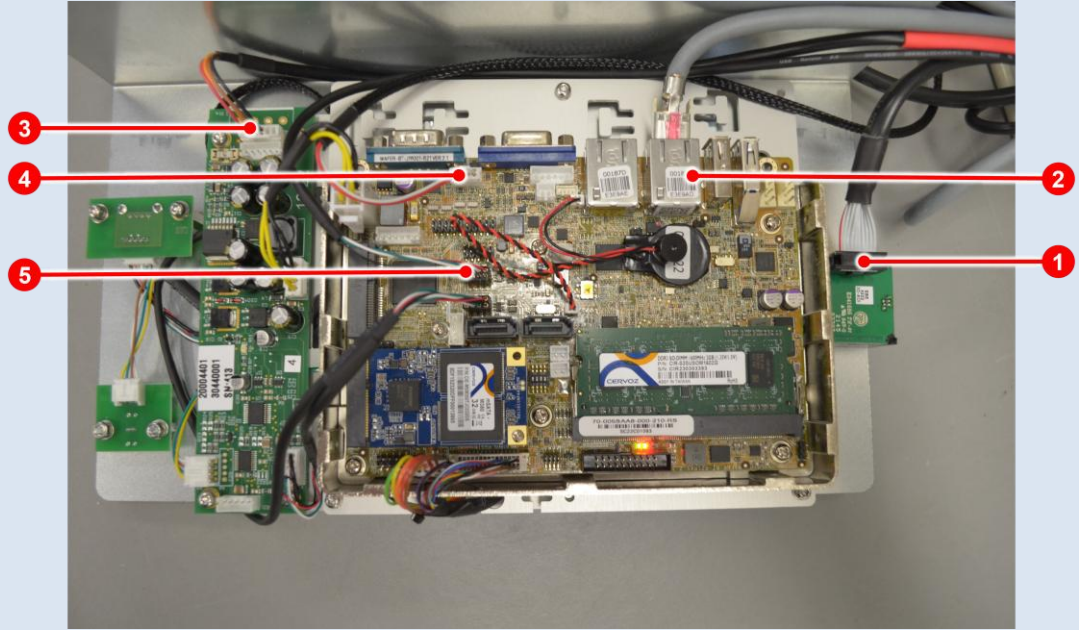

1	Rotary encoder connection
2	LAN connection
3	Connection Power supply LED
4	EPC connection
5	USB connection



Keep red protective cap on **Calibration In** socket in case no calibration gas is connected.

5

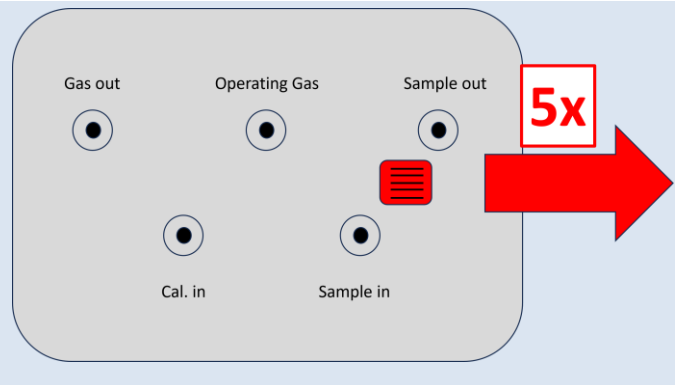

Remove red protective caps from gas sockets. Retain for future use.

6

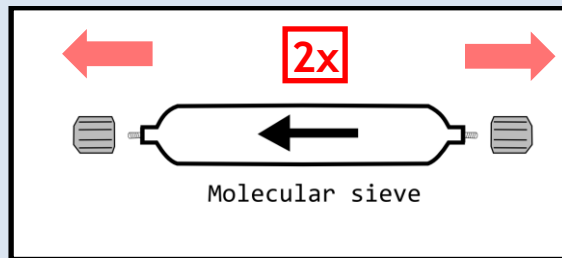

Remove protective caps from molecular sieve. Retain for future use.



Protective caps should be put on gas sockets in case the device is stored or transported.



Make sure that the power switch is set to **OFF** before connecting the power supply.

7

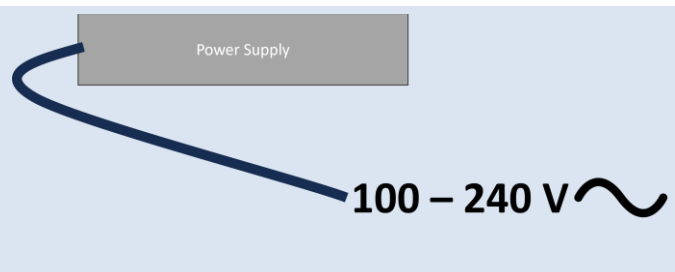

Connect power supply cable to power connection.



Only use stainless steel pressure reducers, PTFE tubes with 3 mm outer diameter and 3 mm Swagelok connectors.

Screw on the Swagelok caps manually and fix them by screwing a further half-turn using a 12 mm open-end wrench.



Make sure that the nominal pressure of the nitrogen source does not fall below 10 bar (1000 kPa).



Do not introduce aggressive gases or liquids into the device.

8

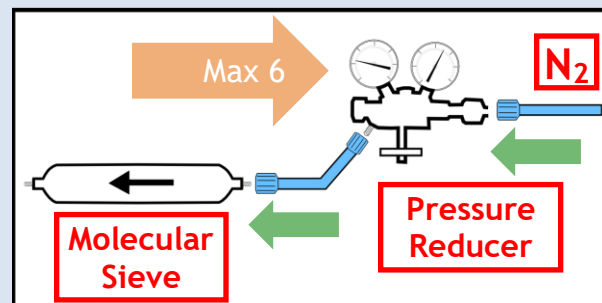

Connect nitrogen (Purity 5.0 or better) source to input of supplied molecular sieve.



Recommended pressure at socket **Operation Gas** is 3 bar - 4 bar (300 kPa - 400 kPa). 6 bar (600 kPa) must not be exceeded.

9

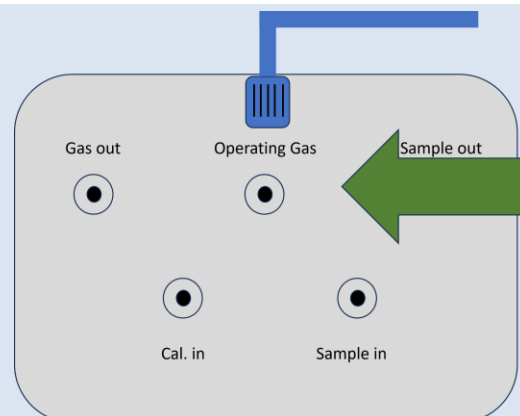

Connect molecular sieve outlet to gas socket **Operating Gas**.

10

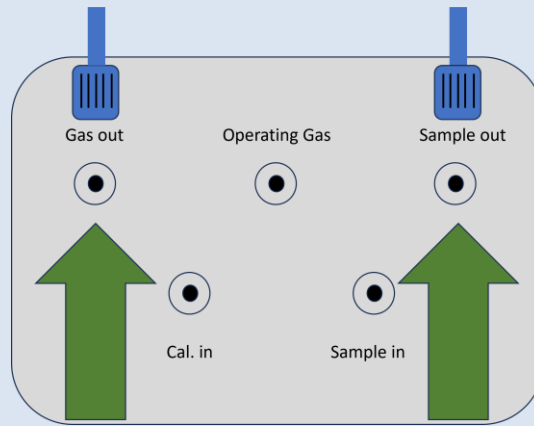

Separately connect sockets **Sample Out** and **Gas Out** to a **Non-sucking exhaust** or to **out-of-doors**.

11

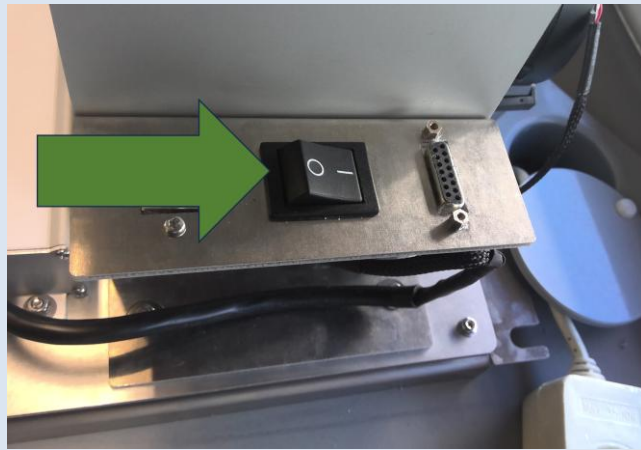

Switch on device.



Minimum bypass flow at sockets **Calibration In** and **Sample In**: 200 ml/min.



WARNING

Only connect gas to **Sample In** In or **Calibration In** with the delivered **bypass adapter**. Incorrect use can destroy the pump/device!

12

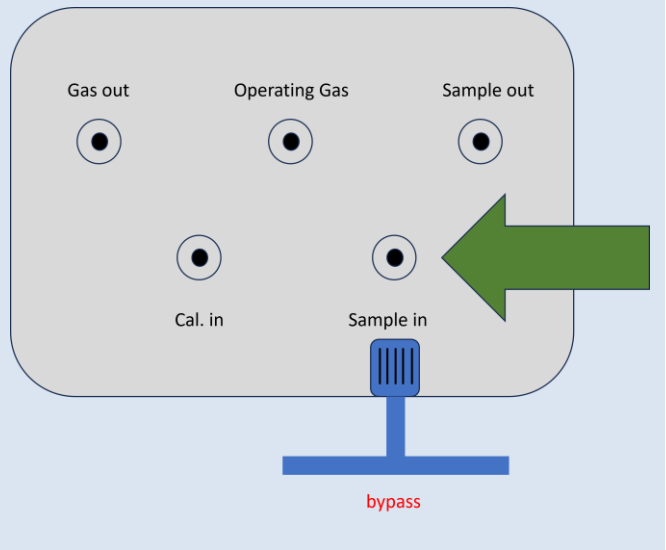

Connect sample gas source to socket **Sample In** with the delivered **bypass adapter**.

13

Option

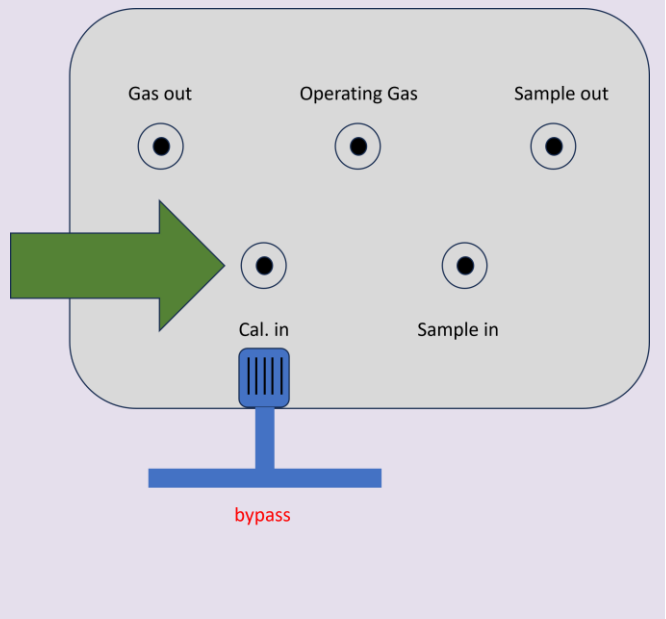

Connect calibration gas source to socket **Calibration In** with the delivered **bypass adapter** in case calibrations are desired.

14

Option

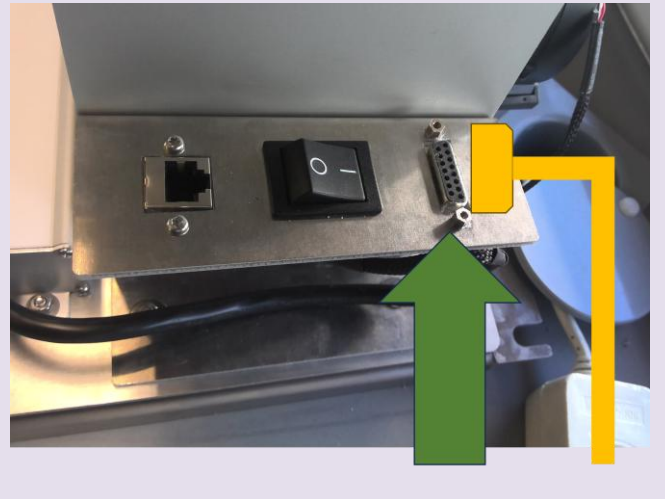

For the output of concentration values through the 0-20 mA current loop connect an appropriate cable to the **Signal Converter - I/O Ports** socket.

14

Option

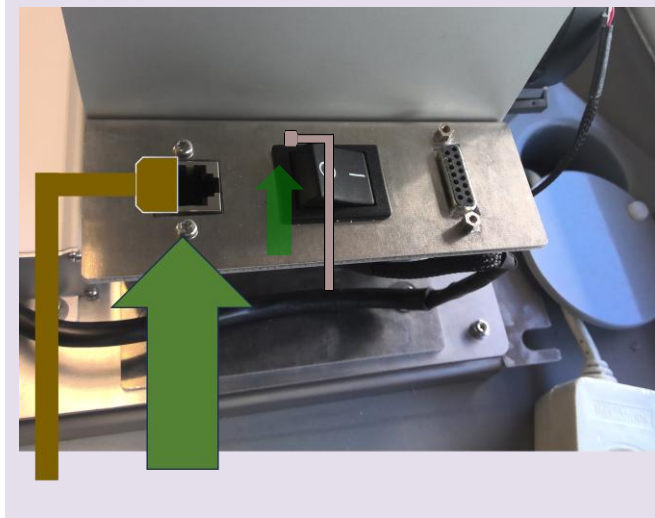

For file transfer via LAN:
Connect the **Ethernet**
socket with an appropriate
Ethernet cable to a LAN.

7 Workflow: Initial Operation / Cleaning

7.1 Using the Cleaning Mode

The device can get contaminated for several reasons. Contaminations show up as additional peaks next to the RIP even when no measurement is running and the system is only connected to the drift gas and carrier gas nitrogen source. If this is the case start the cleaning mode.

Before using the device for the first time or after being disconnected from the nitrogen source for more than one day it must be cleaned to ensure proper operating conditions.

An appropriate cleaning period duration must be chosen depending on how long the device was switched off and on the extent of contamination. It is recommended to clean the device for ~15 hours before operating it for the first time. It is recommended to use High Flows during Cleaning.

7.2 Workflow

Workflow 2: Cleaning Mode



The cleaning process must be completed ~2 hours prior to any measurement so that the internal components can cool down to the required temperatures.

1

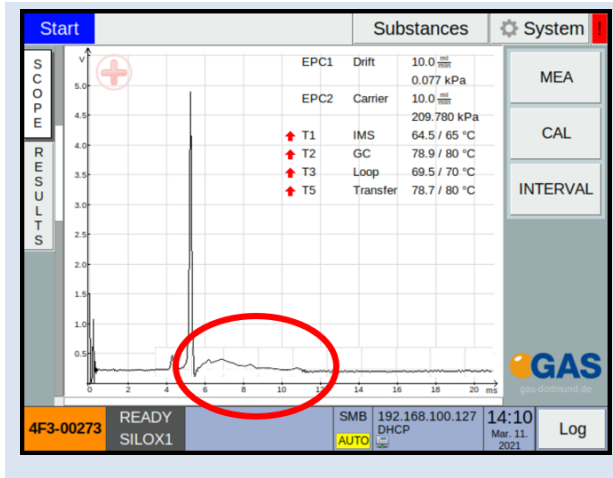

Inspect spectrum for contamination. Control the baseline. Start cleaning when contaminated.

Contamination is indicated by peaks or the disappearing of the RIP.

2

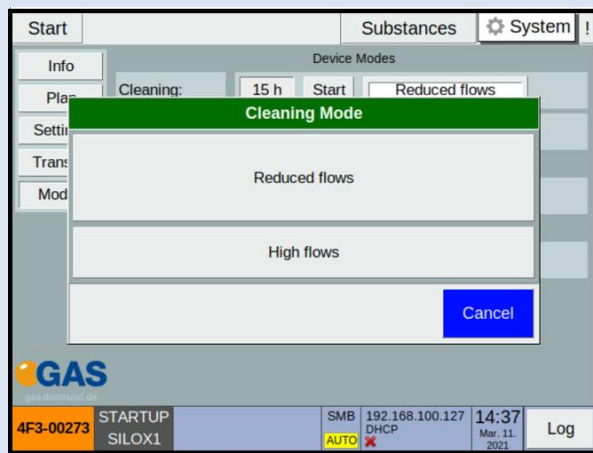

Select:

System > **Modes** > **Cleaning** >
Reduced Flows / High Flows.

Reduced Flows:

Applied for minor contamination: Flows remain unchanged and low (150 mL/min. for IMS and 15 mL/min. for GC column) in order to minimize gas consumption from socket **Driftgas**. Process takes more time.

High Flows:

Applied for stronger contamination: Higher gas consumption from socket **Driftgas**, faster cleaning process (150mL/min IMS and 15 mL/min. for GC-column).

Recommendation: High Flows

3

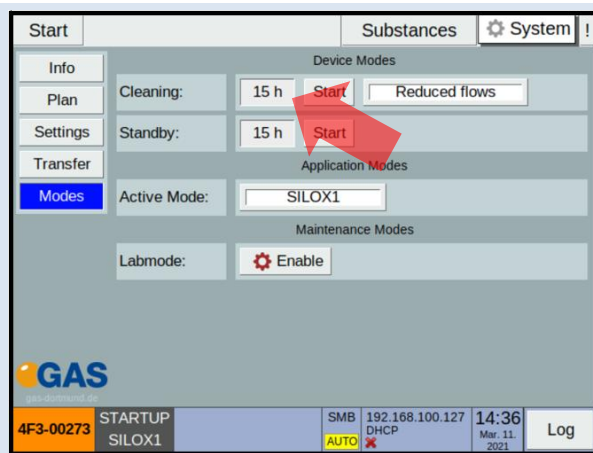

Select duration in hours:

System > **Modes** > **Cleaning** >
For X h.

4

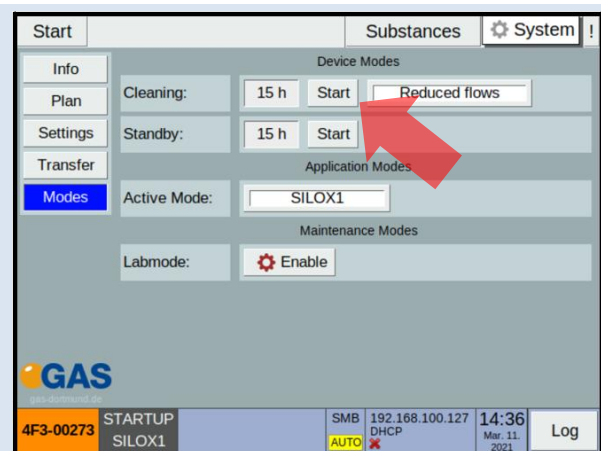

Start cleaning:

System > **Modes** > **Cleaning** > **Start**.

5

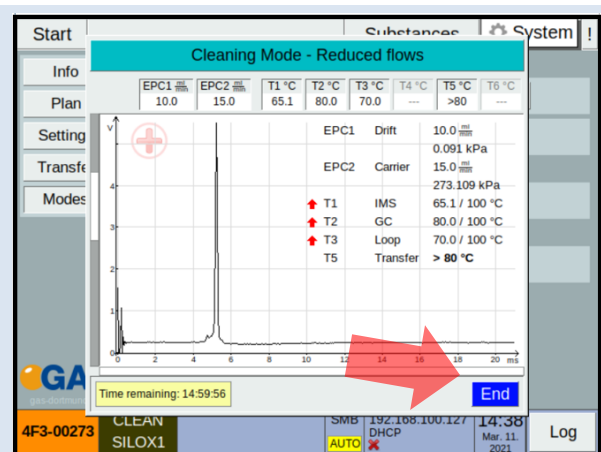

Wait until cleaning process is completed. The process can be stopped at any time with **End**. The Time remaining is indicated.

8 Sampling Methods



INFORMATION!

The following workflow shows the exemplary measurement procedure

1

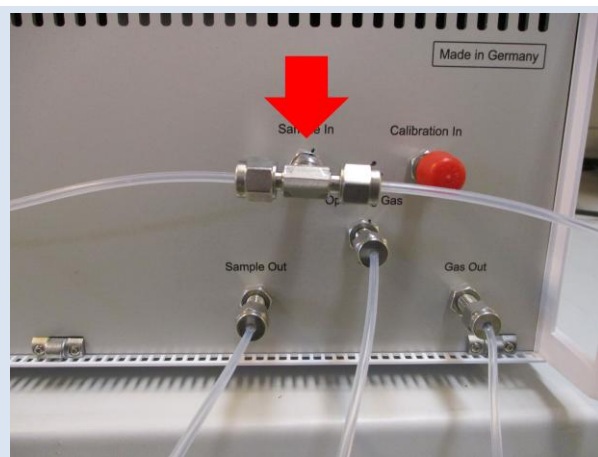

Standard Sampling method 1 (Bypass sampling):

Connect a **Bypass-Adapter** to Sample-In- Connector at the back of the device. Connect a Sample-Gas-Supply to Bypass-Adapter.

Make sure that the bypass gas flow exceeds 200 ml/min.

2

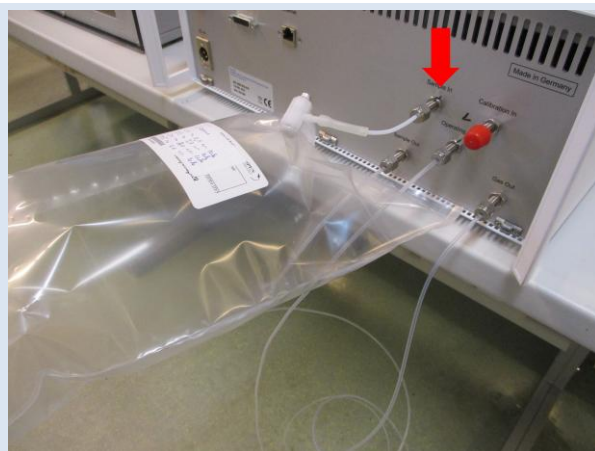

Sampling method 2 Sampling with Samplebag:

Connect the **Samplebag-Outlet** to Sample-In-Connector at the front of the Device.

Open the bag valve and allow the sample to be sucked in.

3

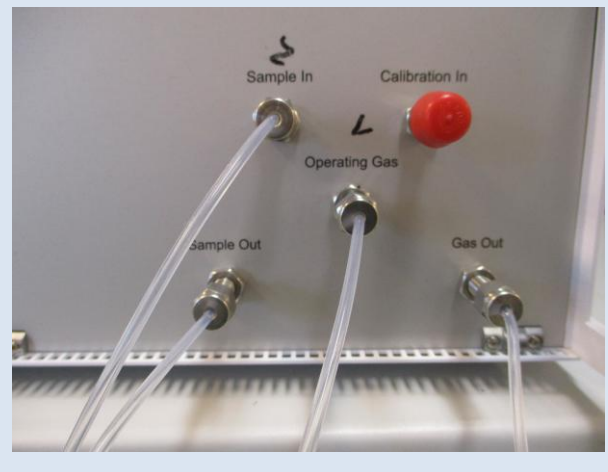

Sampling method 3 (Direct sampling):

Connect a Sample-Gas-Supply to Sample-In-Connector at the front of the Device.

Make sure that the sample source gas is **pressure-free**.

9 Device Parameters During Measurements and Standby

9.1 Introduction



During each measurement and calibration device component values are dynamically modified. These values are displayed in the scope view. Adjusting values are displayed as red.



The values listed below may vary slightly from the actual values due to customization.



The GC-IMS-Silox is designed for routine measurements to quantify Siloxanes. In between measurements the Instrument is set to a Standby mode for minimizing Nitrogen consumption

9.2 Values

Device Component	Values			
	Standby	MEA	CAL	INTERVAL
T1 [IMS]	65 °C	65 °C	65 °C	65 °C
T2 [GC]	80 °C	80 °C	80 °C	80 °C
T3 [Sample Loop]	70 °C	70 °C	70 °C	70 °C
T5 [Transfer Line]	80 °C	80 °C	80 °C	80 °C

EPC1 [Drift Gas]	10 ml/min	150 ml/min	150 ml/min	10/150 ml/min
EPC2 [Carrier Gas]	10 ml/min	5-15 ml/min	5-15 ml/min	5-15 ml/min

10 Workflow: Single Manual Measurement

10.1 Introduction



During a measurement device component values are dynamically modified. These values are displayed in the scope view. See [9 Device Parameters During Measurements and Standby](#).



Any cleaning process must be completed ~2 hours prior to any measurement so that the internal components can cool down to the required temperatures.



The concentration value calculated in a single manual measurement is NOT written to the current loop. Only in **INTERVAL** mode concentration values are written to the current loop.

10.2 Workflow

Workflow 3: Manual Measurement

1

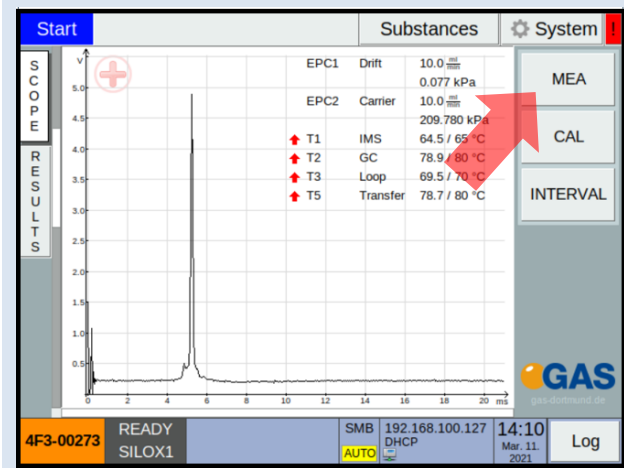

Select mode button: **Start** >

MEA.

2

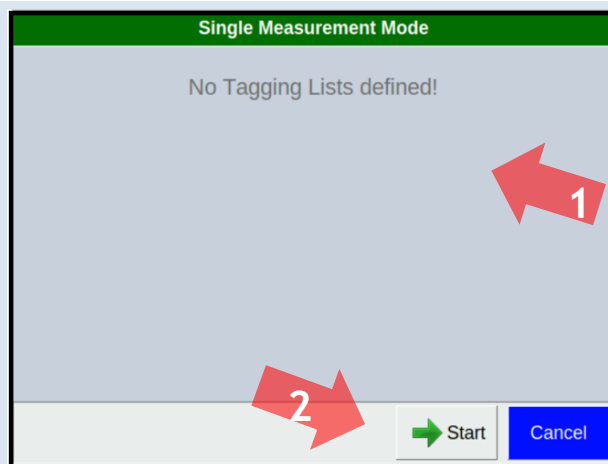

In the start dialog **Single Measurement Mode** by Default no Tags are defined and it is possible start the measurement by clicking the **Start** button. View the [section 14. Workflow Tag Lists](#) for advanced options with Tags

3

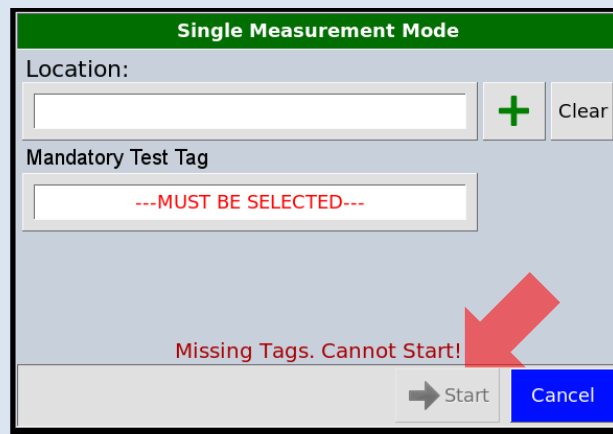

In the case that Tag Lists have been defined the user needs to select mandatory tags like Location and other customized Tags. Once selected and the selection dialog is closed the **Start** Button will turn green. The measurement is started by clicking **Start**.

4

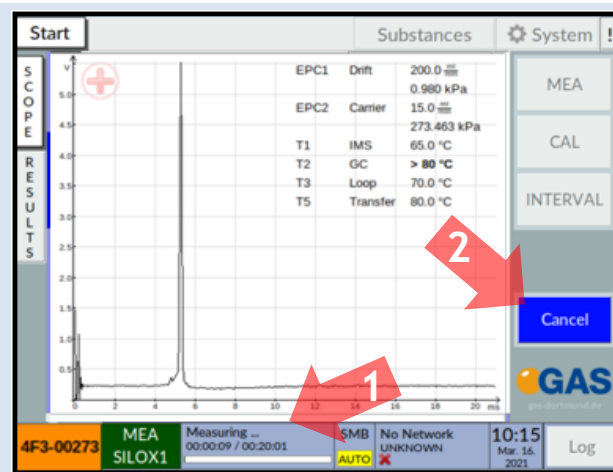

In the status bar the progress of the measurement is displayed (1). With **Start** > **Cancel** the measurement can be cancelled (2).

5

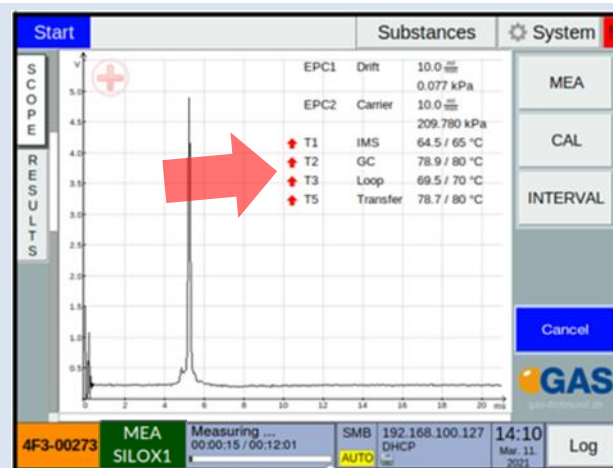

During the process the device parameters are modified. They are displayed on **Start** > **SCOPE**. Adjusting values are displayed in red. In such events, a measurement is invalidated.

See 9 Device Parameters During Measurements and Standby.

6

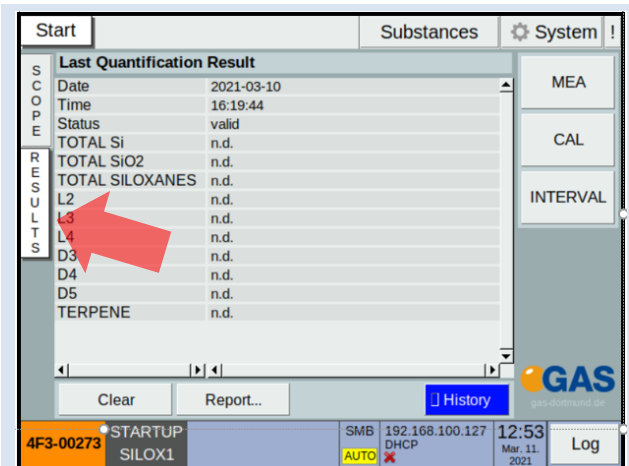

On **Start** > **RESULTS** the result of the measurement is displayed when it has been successful.

See **5.2 Calculating Concentrations** for further information.

7

Option

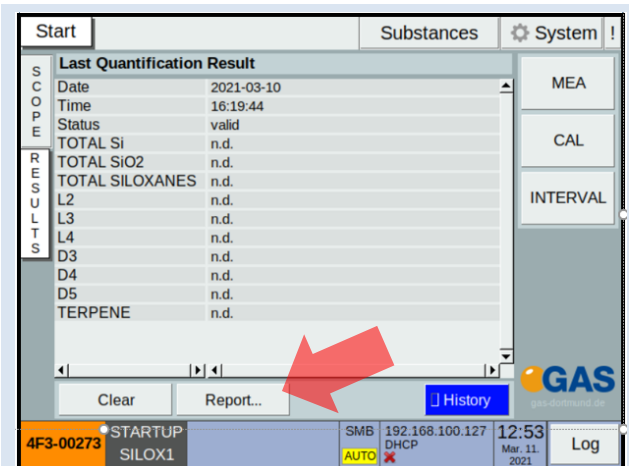

Select **Start** > **RESULTS** > **Report...** to export results to a connected USB device or to a server. It is possible to Enable the display of the **History** or to hide it.

8

Option

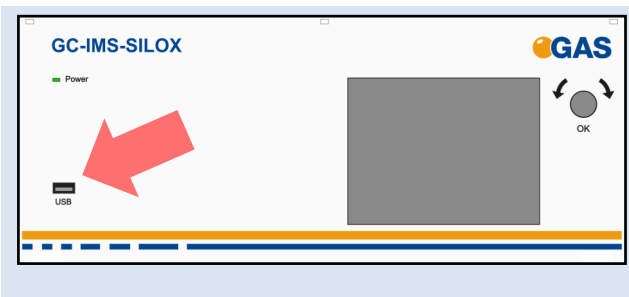

For transfer to USB device:

Connect an USB device (FAT32-formatted) to the **USB** socket at the front side of the housing.

9

Option

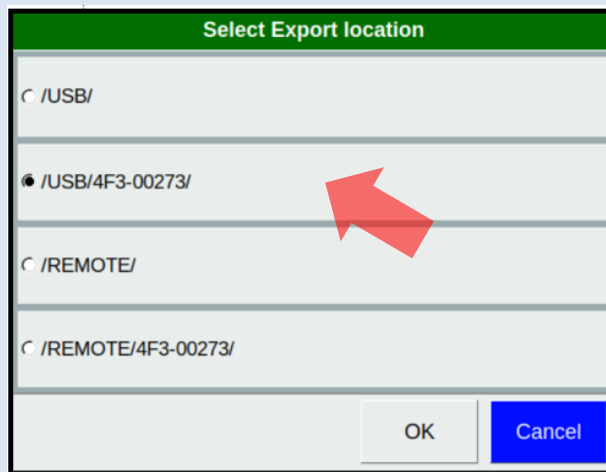

For transfer to USB device:

Select **Create On USB**.

10

Option

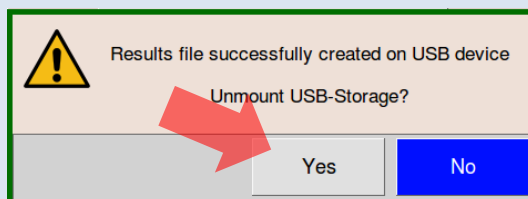

For transfer to USB device:

Select **Yes** to unmount the USB device and close message dialog. The USB device can now be removed from the **USB** socket.

11

Option

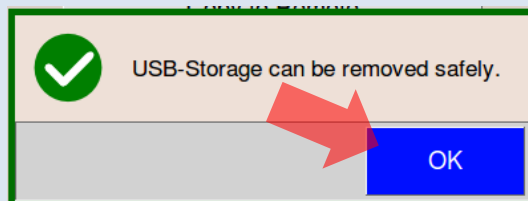

For transfer to USB device:

Select **OK** to close message dialog.

12

Option

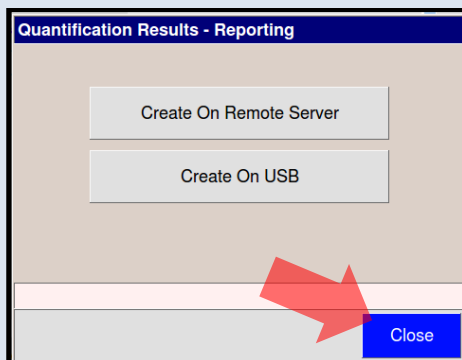

Select **Close** to close dialog.

11 Workflow: Manual Calibration

11.1 Introduction

The purpose of the manual calibration is to fine-tune the calibration the device.



One or more substance calibrations are modified in the calibration process. Make sure that an appropriate calibration gas source is connected to the **Testgas In** socket at the rear of the housing.



A manual calibration only works within certain margins around the factory calibration. When it varies too much from the factory calibration the user is informed, and the results of the manual calibration process are discarded.

11.2 Workflow

Workflow 4: Manual Calibration



During a measurement device component values are dynamically modified. These values are displayed in the scope view. See [9 Device Parameters During Measurements and Standby](#).



Any cleaning process must be completed ~2 hours prior to any measurement so that the internal components can cool down to the required temperatures.

1

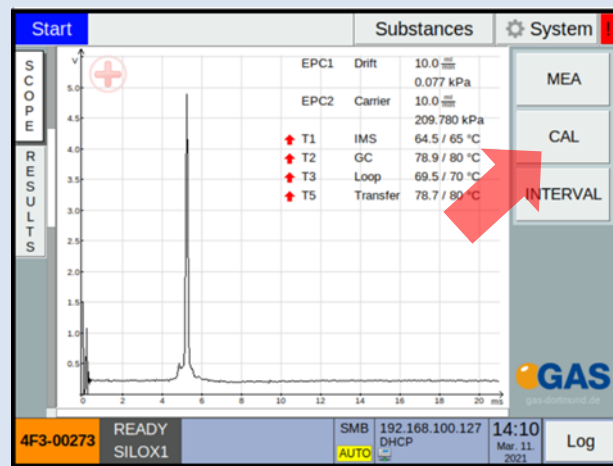

Select mode button: **Start** > **CAL**.

2

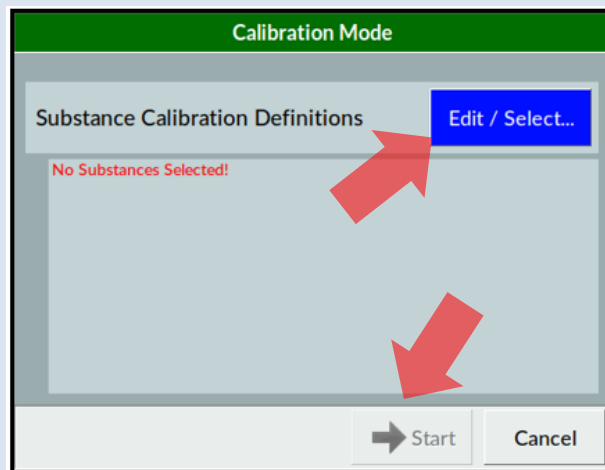

Select in the start dialog.
Calibration Mode > **Substance Calibration Definitions** > **Edit / Select...** for selecting substances that will be calibrated.

Until a Substance is selected **Start** is disabled.

3

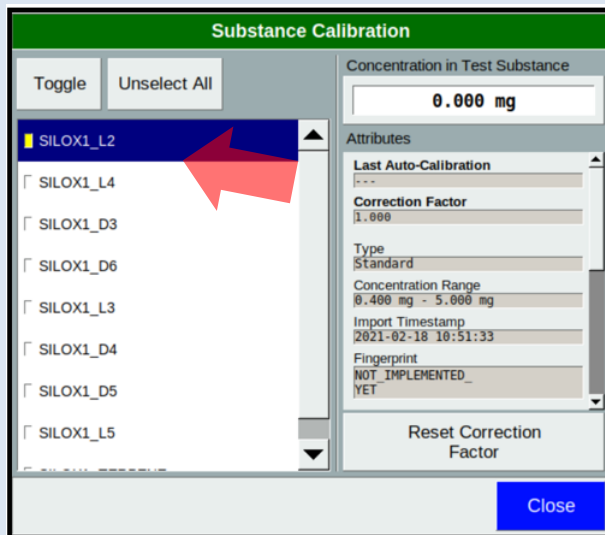

Select all substances that are present in the connected calibration gas source and should be calibrated. Selected substances are displayed with a Yellow mark.

4

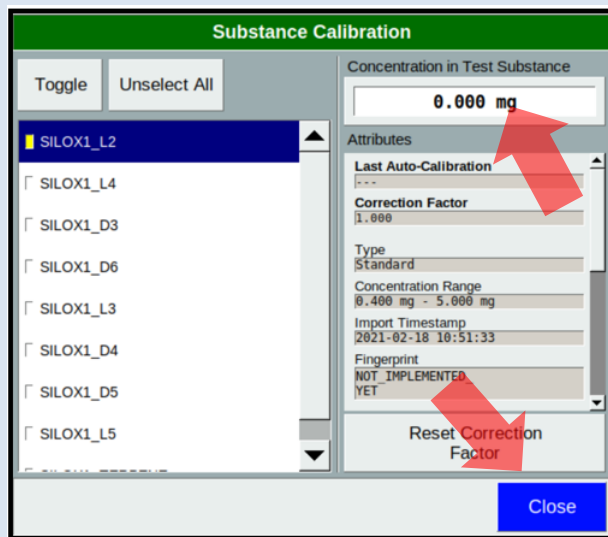

For all selected substances enter their concentration in the connected calibration gas source connected to the **Testgas In** socket.

Close dialog with **Close**.

5

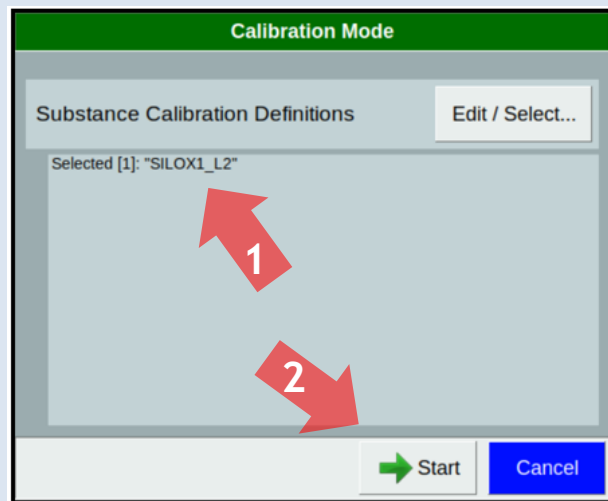

At least one substance must be selected to start the process (1). **Start** (2) is showing a green arrow and is enabled

Close the dialog with **Start** (2). The process is started.

6

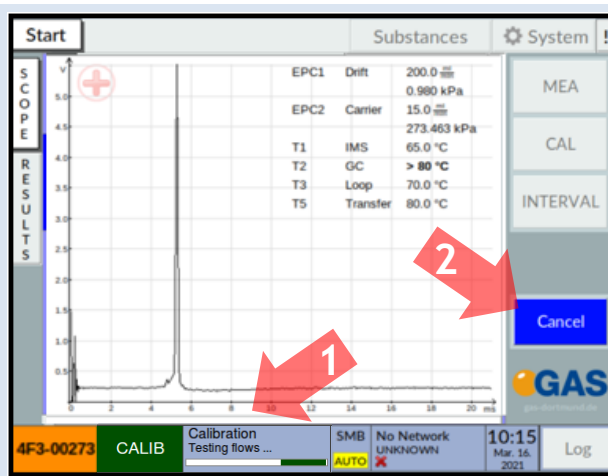

In the status bar the progress of the measurement is displayed (1). With **Start** > **Cancel** the measurement can be cancelled (2).

7

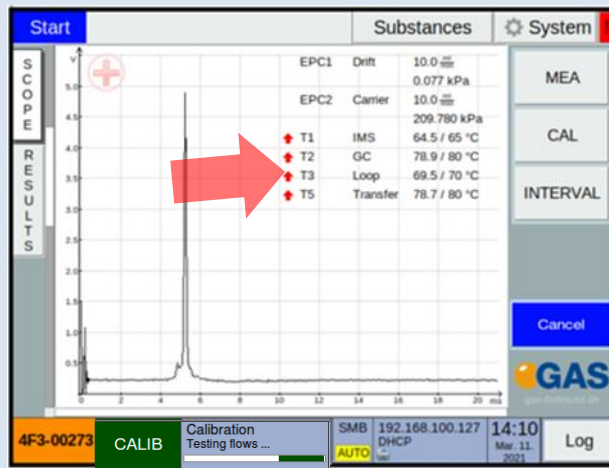

During the process the device parameters are modified. They are displayed on **Start** > **SCOPE**. Adjusting values are display in red.

See **9 Device Parameters During Measurements and Standby**.

8

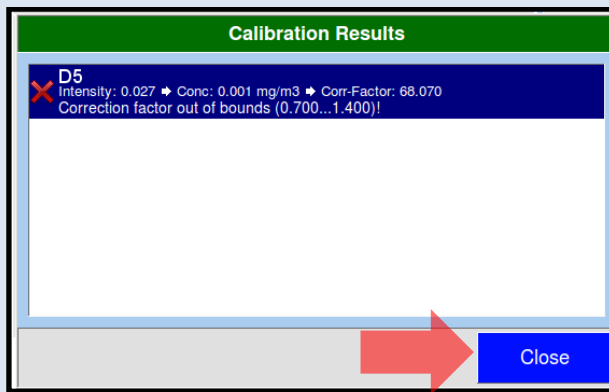

The result of the calibration process - success or failure - is displayed in a dialog.

Close the dialog with **Close**.

12 Workflow: Running Automatic Measurements

12.1 Introduction to the Interval Mode

In the interval mode scheduled measurements and calibrations are performed in a continuous and predefined sequence. It is possible to activate also Calibrations and Cleaning. The latest release of GC-IMS-Silox Firmware provides a full flexibility to define the measurement intervals, as well as calibration and cleaning intervals.



All substance calibrations associated with the selected application mode are modified within the interval mode when calibrations are activated. Make sure that an appropriate calibration gas source is connected to the **Testgas In** socket at the rear of the housing.



A calibration only works within certain margins around the factory calibration. When it varies too much from the factory calibration the user is informed and the results of the calibration process are discarded.

Note: A calibration has higher priority than a measurement. When a calibration and a measurement collide according to the interval scheduling the measurement is skipped (illustration shows example durations that may differ from actual durations) and a Cleaning Cycle overrides Calibration and Measurement with top priority:

Time	Day 1	Day 2	Day 3	Day 4	Day 5	Day 6	Day 7	Day 8	Day 9	Day 10	Day 11	Day 12	Day 13	Day 14
0		MEA	MEA	MEA	MEA	MEA	MEA	MEA	MEA	MEA	MEA	MEA	MEA	CLEAN
1														CLEAN
2		MEA	MEA	MEA	MEA	MEA	MEA	MEA	MEA	MEA	MEA	MEA	MEA	CLEAN
3														CLEAN
4		MEA	MEA	MEA	MEA	MEA	MEA	MEA	MEA	MEA	MEA	MEA	MEA	CLEAN
5														Cool D
6		MEA	MEA	MEA	MEA	MEA	MEA	MEA	MEA	MEA	MEA	MEA	MEA	Cool D
7														
8		MEA	MEA	MEA	MEA	MEA	MEA	MEA	MEA	MEA	MEA	MEA	MEA	MEA
9														
10		MEA	MEA	MEA	MEA	MEA	MEA	MEA	MEA	MEA	MEA	MEA	MEA	MEA
11														
12	MEA	MEA	MEA	MEA	MEA	MEA	MEA	MEA	MEA	MEA	MEA	MEA	MEA	MEA
13														
14	MEA	MEA	MEA	MEA	MEA	MEA	MEA	MEA	MEA	MEA	MEA	MEA	MEA	MEA
15														
16	MEA	MEA	MEA	MEA	MEA	MEA	MEA	MEA	MEA	MEA	MEA	MEA	MEA	MEA
17	CAL	CAL	CAL	CAL	CAL	CAL	CAL	CAL	CAL	CAL	CAL	CAL	CAL	CAL
18	MEA	MEA	MEA	MEA	MEA	MEA	MEA	MEA	MEA	MEA	MEA	MEA	CLEAN	MEA
19													CLEAN	
20	MEA	MEA	MEA	MEA	MEA	MEA	MEA	MEA	MEA	MEA	MEA	MEA	CLEAN	MEA
21													CLEAN	
22	MEA	MEA	MEA	MEA	MEA	MEA	MEA	MEA	MEA	MEA	MEA	MEA	CLEAN	MEA
23													CLEAN	

Figure 6: Interval Mode - Exemplary Interval programmed which fills a 2 weeks overall recurring interval - a measurement every 2 hours, a calibration every day at 17:00 and a cleaning cycle at the end of day 13

12.2 Workflow

Workflow 5: Define the Interval Mode



Carefully plan your Interval schedule, consider the minimum time required for a measurement/calibration and consider the implemented hierarchy of priorities in case of coincidence: Cleaning has priority over Calibration and Calibration has priority over Measurement.



During a measurement device component values are dynamically modified. These values are displayed in the scope view. See [9 Device Parameters During Measurements and Standby](#).



Any cleaning process must be completed ~2 hours prior to any measurement so that the internal components can cool down to the required temperatures.

This must be taken into account also if cleaning cycles are introduced in the interval schedule



Before every measurement and before every calibration the RIP and the default parameters are tested. In case this test fails the measurement is invalidated or the calibration is skipped.

1

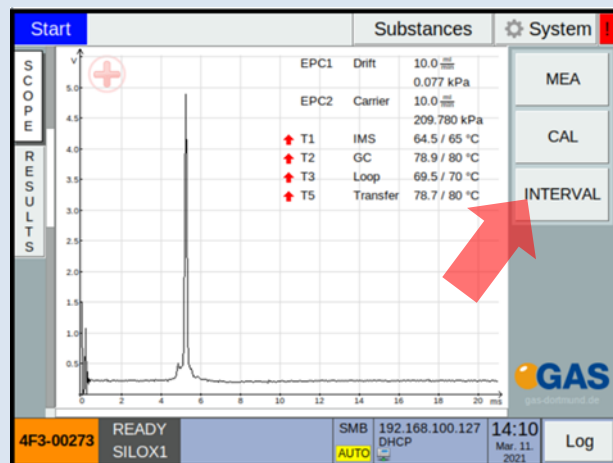

Select mode button: **Start** >

INTERVAL.

2

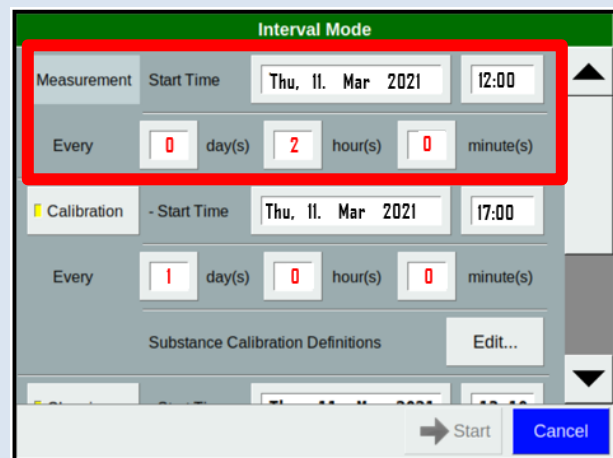

Select in the start dialog

Interval Mode > **Measurement**

- Start Time / **Every**: The start

of the the first measurement and the repetition rate can be defined. Example: Defined

Start Time and MEA **Every** 2

hours.

The minimum interval time set in **Every** must be longer than the Measurement Program.

3

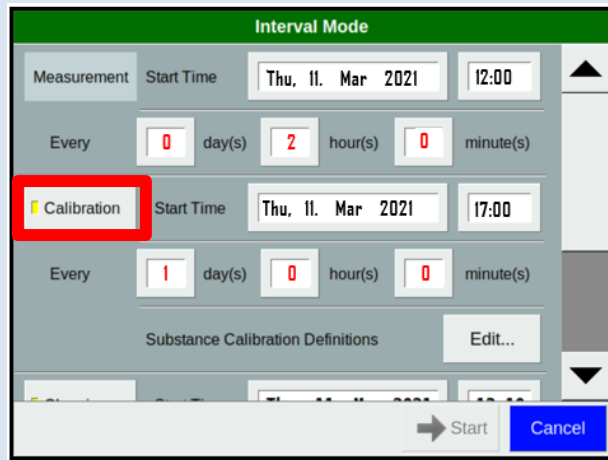

Activate or deactivate calibrations with **Interval Mode** > **Calibration**.

As soon as Calibration is activated the Substance Calibration Definitions must be checked and updated if required

4

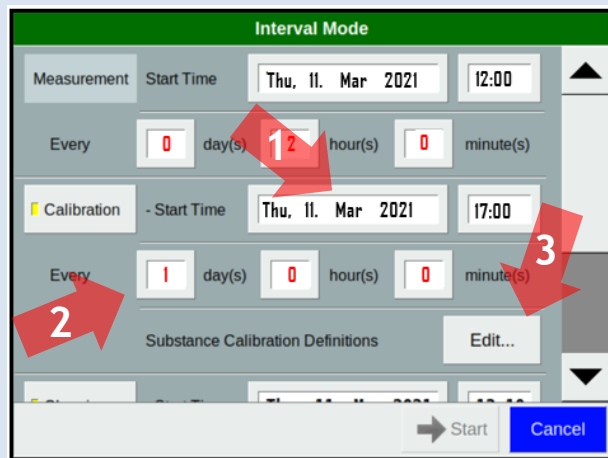

With **Calibration** > **Start Time** (1)/ **Every** (2) select the start point of the first calibration and the repetition rate.

With **Substance Calibration Definitions** > **Edit...** (3) the loaded substance calibrations can be reviewed.

Example:
Calibration every day at 17:00

5

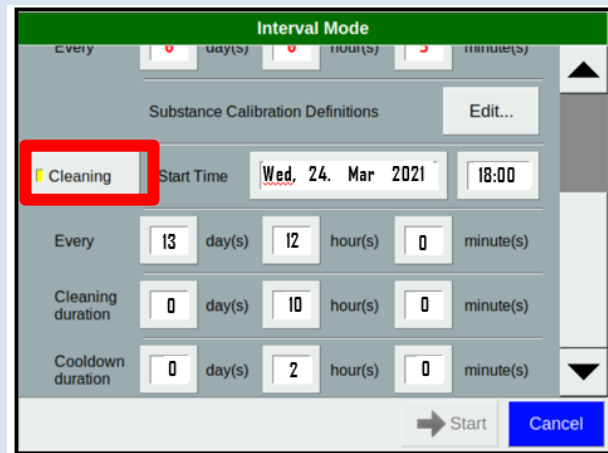

With **Calibration** > **Cleaning** it is possible to also enable Cleaning cycles and **Cleaning Start time** can be defined

Interval Mode

Every 0 day(s) 0 hour(s) 0 minute(s)

Substance Calibration Definitions Edit...

Cleaning - Start Time Wed, 24. Mar 2021 18:00

Every 13 day(s) 12 hour(s) 0 minute(s)

Cleaning duration 0 day(s) 10 hour(s) 0 minute(s)

Cooldown duration 0 day(s) 2 hour(s) 0 minute(s)

Start Cancel

With **Cleaning - Every/**
Cleaning Duration and
Cooldown Duration select the
 required Timing

Example: 13 days after starting
 the Interval Mode on March 11,
 2021 the first cleaning cycle is
 started at 18:00 for 10 hours,
 followed by a cool-down of 2
 hours.

Consecutive measurements will
 be re-initiated at 6 am in the
 morning of day 14 at the
 defined measurement cycle
 frequency.

6

Interval Mode

Substance Calibration Definitions Edit...

Cleaning - Start Time Sun, 21. Mar 2021 0:00

Every 0 day(s) 4 hour(s) 2 minute(s)

Cleaning duration 0 day(s) 1 hour(s) 0 minute(s)

Cooldown duration 0 day(s) 1 hour(s) 0 minute(s)

Start Cancel

After all entries are defined
 the defined Interval can be
 started

Close the dialog with **Start**.
 The Interval Mode is started. In
 the shown settings the
 Cleaning will not be included in
 the interval schedule.

7

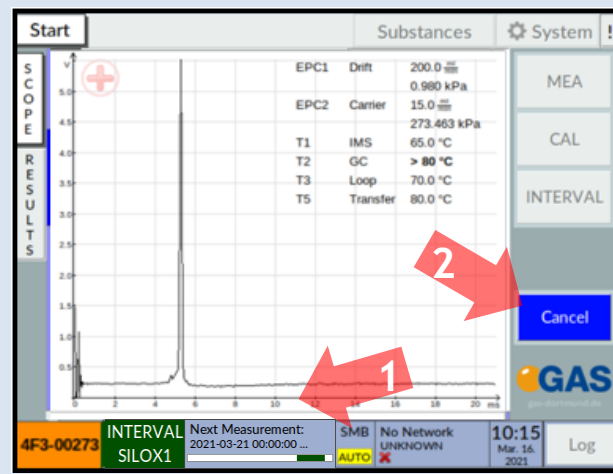

In the status bar the starting point of the next measurement or calibration and the progress of a measurement or calibration are displayed (1). With **Start** > **Cancel** the process can be cancelled (2).

8

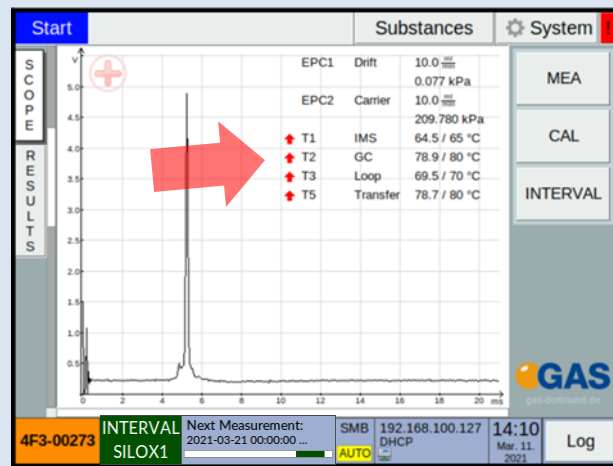

During the process, the device parameters can be modified. They are displayed on **Start** > **SCOPE**. Adjusting values are display in red. See **9 Device Parameters During Measurements and Standby**.

Start		System	Info
Last Quantification Results			
		09.01.2017 / 09:46:38	
TOTAL Si	1.3 mg/m ³	MEA	
TOTAL SiO ₂	2.7 mg/m ³	CAL	
TOTAL SILOXANES	3.8 mg/m ³	INTERVAL	
L2	0.1 mg/m ³		
L3	1.8 mg/m ³		
L4	0.2 mg/m ³		
L5	n.d.		
D3	0.7 mg/m ³		
D4	0.5 mg/m ³		
D5	0.5 mg/m ³		
D6	n.d.		
Clear		Report...	History
1F3-00065	READY SILOX1	SMB 192.168.100.59 DHCP AUTO	10:13 Sep. 16. 2016 Log

On **Start** > **RESULTS** the result of the measurement is displayed when it has been successful (1).

Results can be copied to a connected USB device or a server with **Start** > **RESULTS** > **Report...** (2).

The concentration of the main substance is outputted to the current loop.

See **5.2 Calculating Concentrations** for further information.

13 Workflow: Current Loop Setup

13.1 Introduction

The device transmits the measured concentration of the main substance as electrical current to the 0-20 mA-current loop interface.

This is done only in the interval mode. See [12 Workflow: Running](#).

Application Mode	Output Substance
SILOX1	Total Si
SILOX2	Total Si

For further information on measurement concentration ranges see [5.2 Calculating Concentrations](#).

The concentration range of the output substance is mapped to a sub-interval within 0-20 mA.

Outside this sub-interval a mA-error value and a mA-idle value can be defined.

The error value is set when a measurement has failed to produce a valid concentration.

The idle value is set when no valid concentration is available yet or when the interval mode is not active.

13.2 Electrical Interface

The current loop has to be connected to the **Signal Converter - I/O Ports** socket at the rear of the housing according to the following diagram:

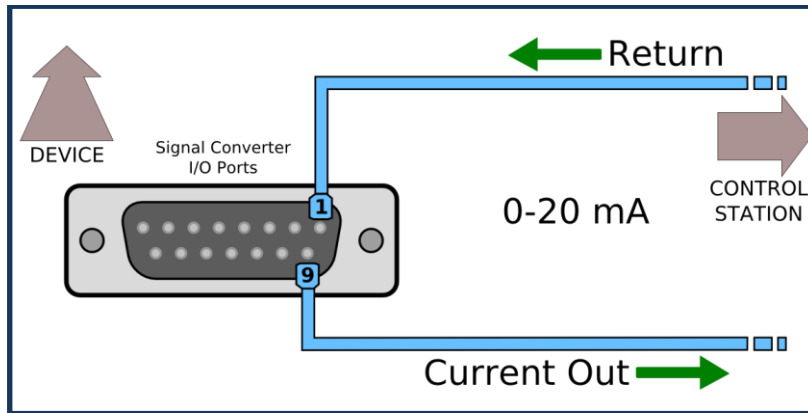

Figure 7: Current Loop - Electrical Interface

13.3 Configuring the Current Loop

Workflow 6: Current Loop Setup



For concentration value output through the 0-20mA current loop the socket **Signal Converter - I/O Ports** at the rear of the housing must be connected with an appropriate cable to a display unit.

1



Open dialog:

System > Settings > Current Loop > Settings...

2

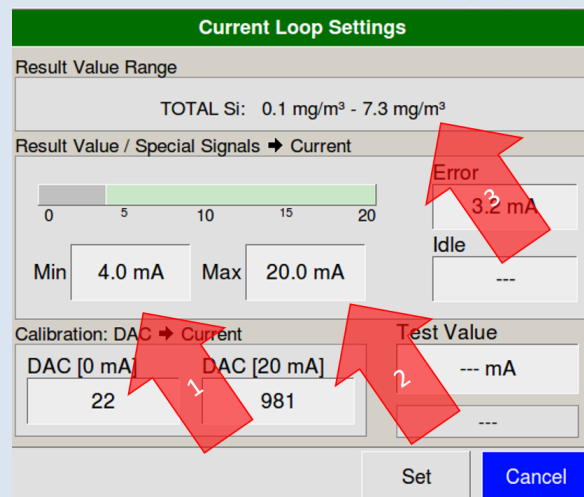

With Result Value / Special Signals -> Current > Min (1) and Max (2) set the mapping of the concentration range (3) to the range 0 mA - 20 mA.

Here:

0.1 mg/m³ → 4.0 mA
7.3 mg/m³ → 20.0 mA

3

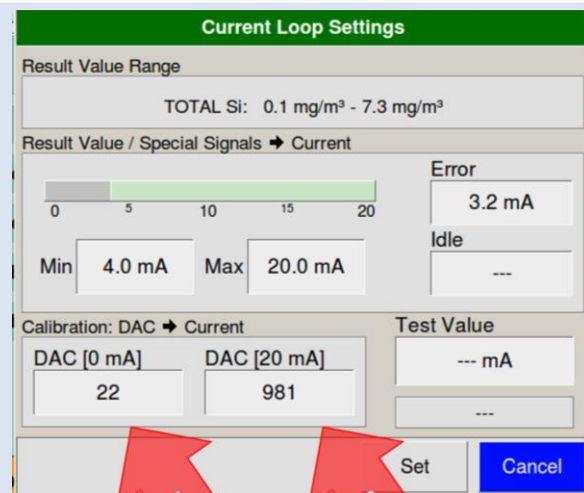

With Result Value / Special Signals -> Current > DAC [0 mA] and DAC [20 mA] calibrate to 0-20 mA by measuring the output Value in mA on an external display unit. The values in the Screenshot are preset factory default values and have to be finetuned by the user.



The values for DAC [0 mA] and DAC [20 mA] are factory default values. The correct values for DAC [0 mA] and DAC [20 mA] must be adapted by the user.

4

When desired set mA values for error and idle state with **Result Value / Special Signals -> Current** > **Error** and **Idle**.

5

Close the dialog with **Set**.

Current Loop Settings	Values (Min, Max, Default and Example Values)
Result Value-Range	Min 0mA, Max 20 mA (Default: 4,0 mA - 20 mA)
DAC-Range	Depending on Current Loop generation Min 0 mA - Max 1024 mA (Example: 22 mA - 981 mA) Min 0 mA - Max 65535 mA (Example: 20 mA - 54559 mA)
Error Value	Min 0 mA, Max 20 mA (Default: 3,2 mA)
Idle Value	Min 0 mA, Max 20 mA (any value except Error Value and Result Value Range)

14 Workflow: Tag Lists

14.1 Introduction

The user can define lists of tags that can be associated with measurement data. When such lists are defined the user is asked to select a tag from each list before a manual measurement is started.

A tag list has a name, e.g. `Location`.

It can be defined as mandatory. Mandatory tags must be selected before a measurement can be started. For example, it may be the policy of the operator's company to attribute the attachment of a location compulsory to the measurement data.

It can be defined as addible. Addible tag lists can be extended before a manual measurement is started. For example, a new measurement location identifier can be added to the list `Location` when arriving at a measurement location not previously used.

Tag lists can be transferred to and from the device either in a JSON format file or in CSV format file. For further information on the tag list file formats see [20 Tag Lists File Formats](#).

Limits to Tag Lists:

- The maximum number of tag lists in the device is 50.
- The maximum number of tags in one single tag list is 500.
- The maximum number of characters in a tag list name is 24.

- Valid characters: Upper and lower case letters (without German umlauts, without ß), numbers and spaces
- The maximum number of characters in a tag is 32.
- Valid characters: upper and lower case letters (without German umlauts, without ß), numbers, spaces, special characters: @_\$\$%+-(!)!:”’;/?.,

14.2 Creating and Editing Tag Lists

Workflow 7: Creating and Editing Tag Lists

1

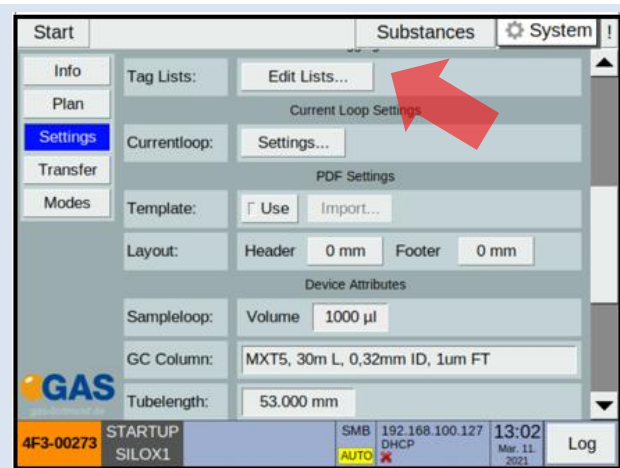

Tag lists can be managed in **System** > **Settings** > **Tag Lists** > **Edit Lists...**

Hint:

The Settings View has all important Settings of the instrument - use the Scrollbar

2

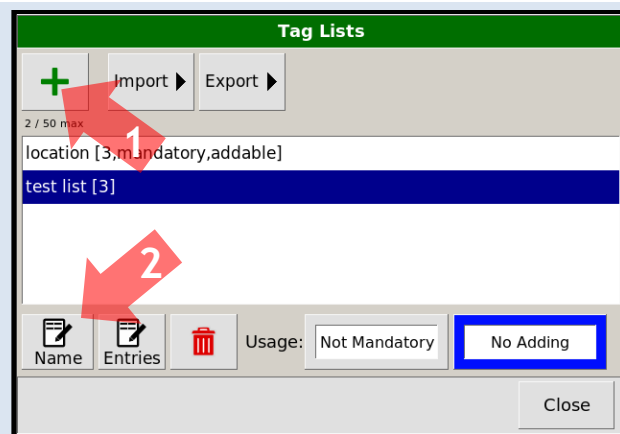

For a new tag list select **+** (1).

For editing the name of an existing list select **Name** (2).

3

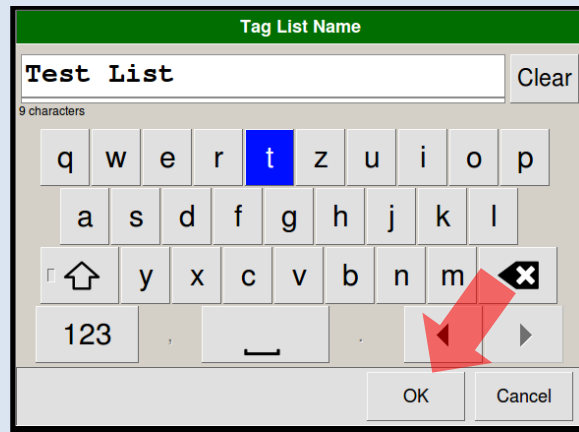

Enter name of the tag list.
Close dialog with **OK**.

4

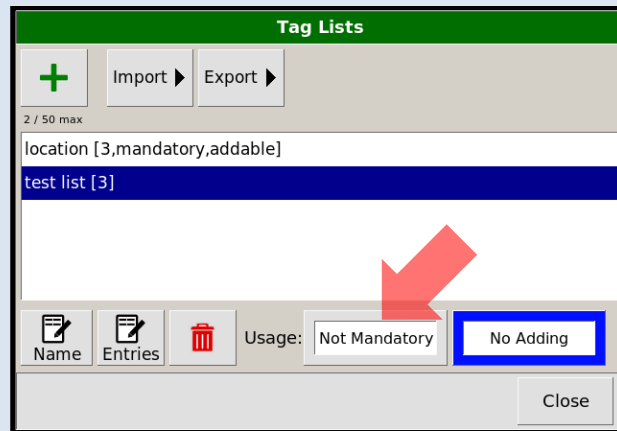

Not Mandatory: Selecting this tag is not required before a manual measurement is started.

Mandatory: Operator must select this tag before a manual measurement can be started.

5

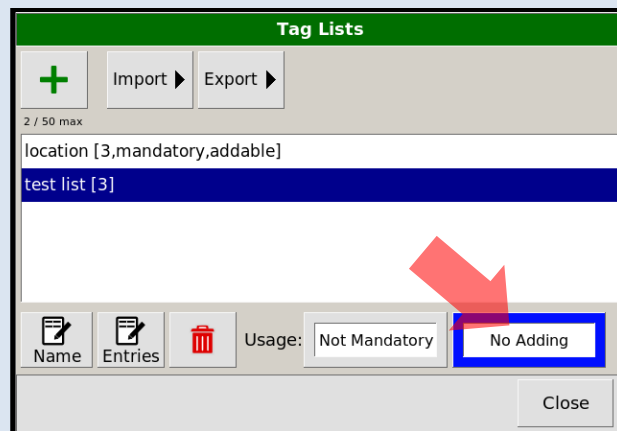

Adding Allowed: Operator can add new tag to this list when asked to select a tag.

No Adding: Only the predefined tags can be selected.

6

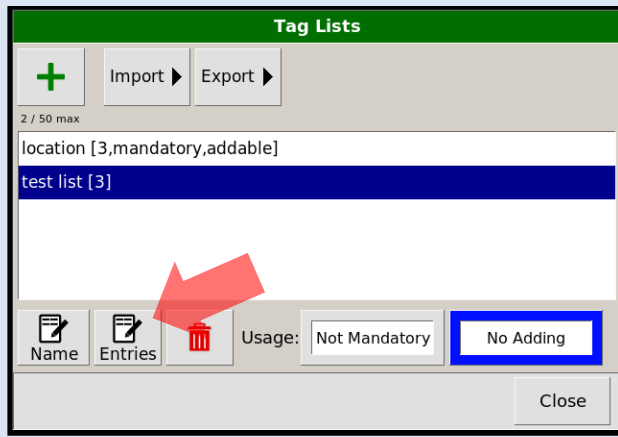

For editing the tags in the list select **Edit Entries**.

7

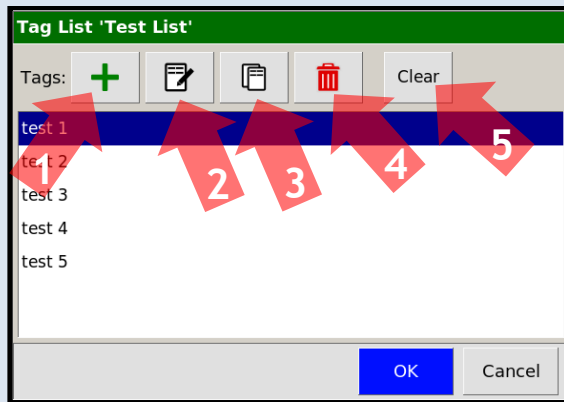

Add tags with **+** (1).

Edit tags with the buttons **Edit**(2), **Copy**(3), **Delete**(4) and **Clear**(5).

8

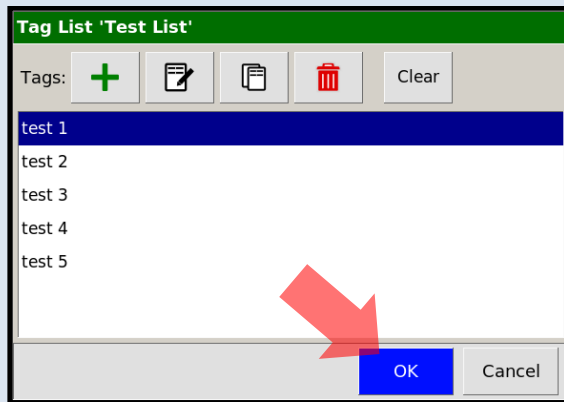

Close the dialog with **OK**.

9

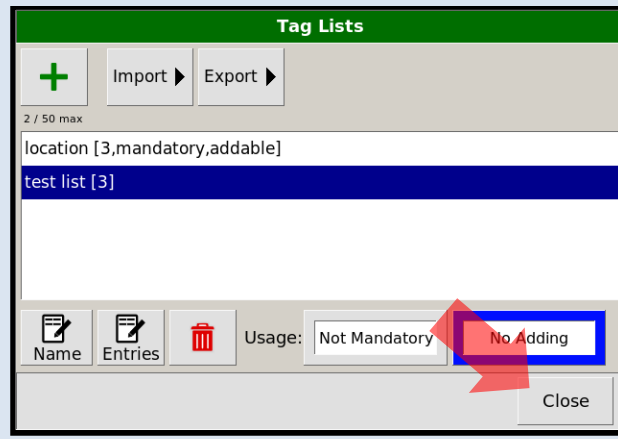

Close the dialog with **Close**.

14.3 Usage

1

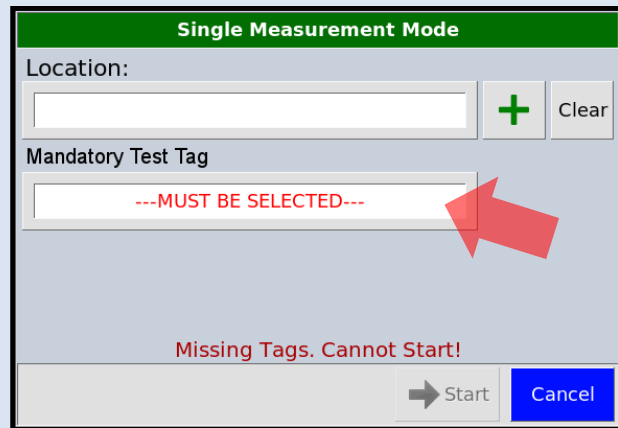

When starting a manual measurement:

In the start dialog **Single Measurement Mode** select tags. Click on a tag value field to open the selection dialog. Mandatory tags must be selected before start.

2

Location

1

example 1

example 2

example 3

example 4

example 5

example 6

6

Cancel

In the selection dialog select the desired tag. The dialog closes automatically.

3

Single Measurement Mode

Location:

Mandatory Test Tag

---MUST BE SELECTED---

Missing Tags. Cannot Start!

Start Cancel

Use the **+** button to add a tag to the list that has been defined as addible.

4

Single Measurement Mode

Location:

Mandatory Test Tag

---MUST BE SELECTED---

Missing Tags. Cannot Start!

Start Cancel

Use the **Clear** button to empty a tag field.

5

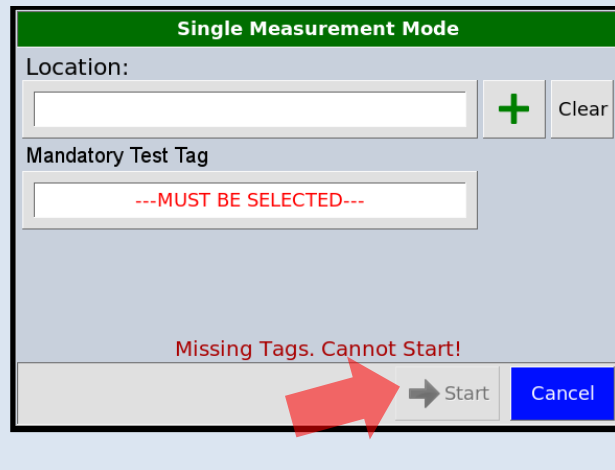

The **Start** button is deactivated until all mandatory tags are selected. In this case **Mandatory Test Tag** must be selected first. **Location** as a non-mandatory tag can be left empty.

14.4 Exporting Tag Lists

Workflow 8: Exporting Tag Lists

1

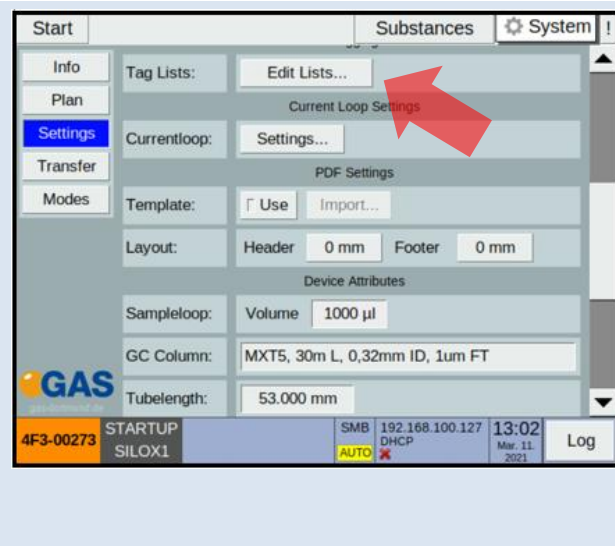

Tag lists can be managed in **System** > **Settings** > **Tag Lists** > **Edit Lists...**

2

Option

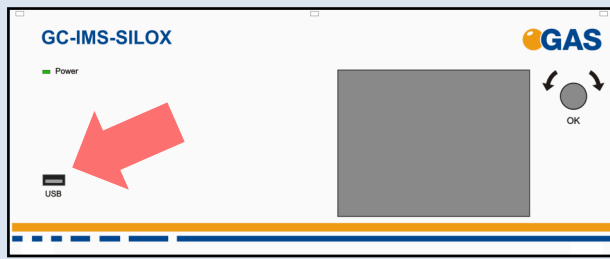

For transfer to USB device:

Connect an USB device (FAT32-formatted) to the **USB** socket at the front side of the housing.

3

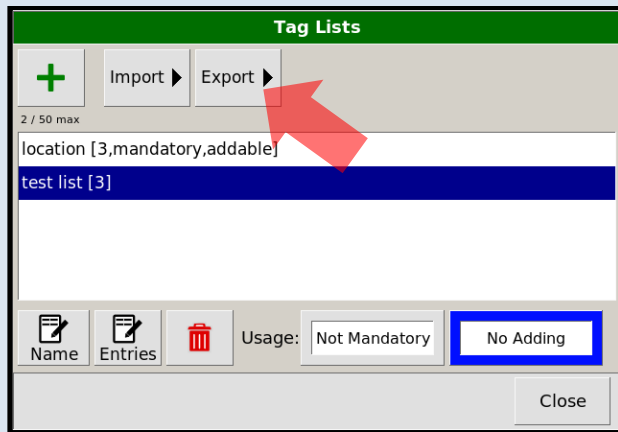

For exporting tag lists select **Export**.

4

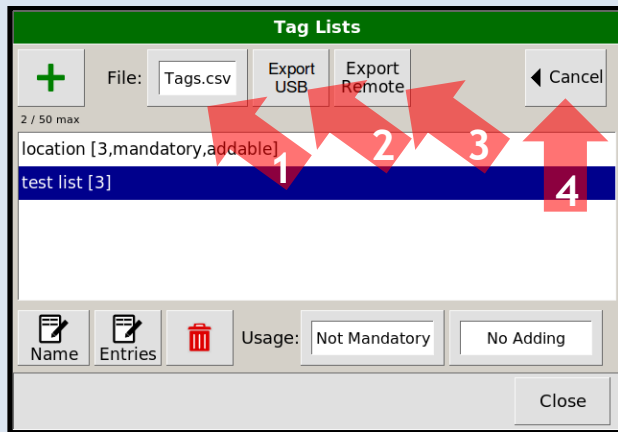

Select the output format with **File (1): Tags.json** or **Tags.csv**

Start the export process to a connected USB storage device **Export USB (2)**.

or

start the export process to a connected remote server with **Export Remote (3)**.

or

close the export menu with **Cancel (4)**.

5

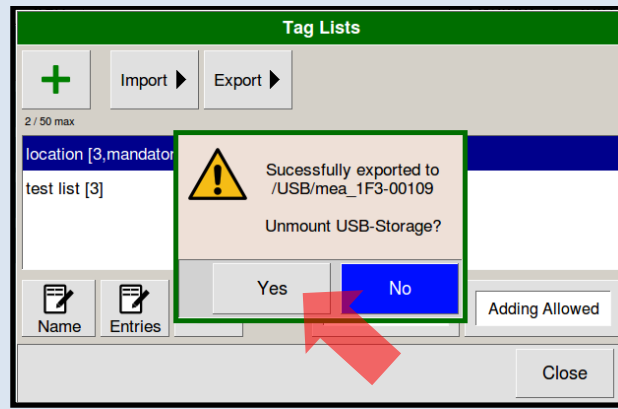

When the export process was successful a dialog is displayed showing the export path.

Select **Yes** to unmount the USB storage device so that it can be removed safely.

6

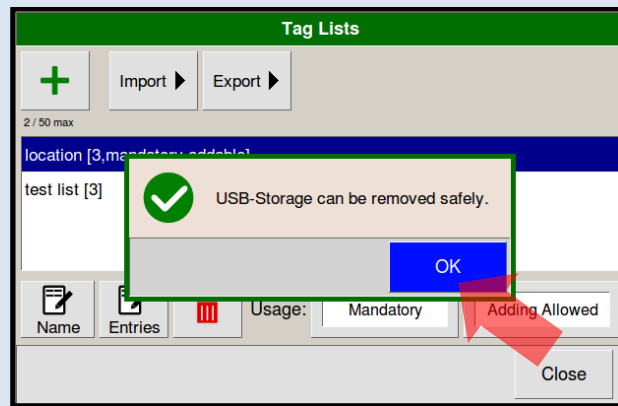

The USB storage device can be removed safely. Select **OK**.

7

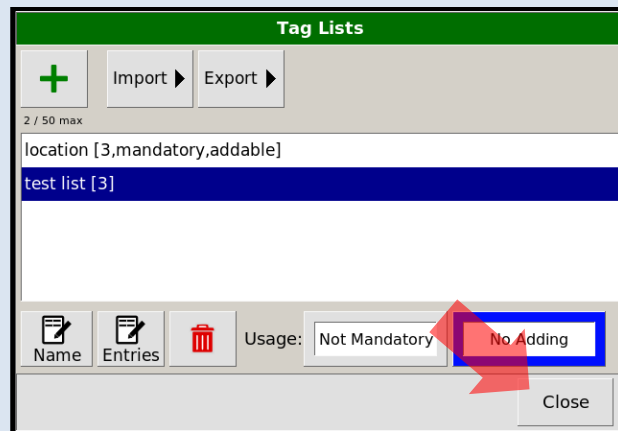

Close the dialog with **Close**.



The export process is completed.

14.5 Importing Tag Lists

Workflow 9: Importing Tag Lists

1

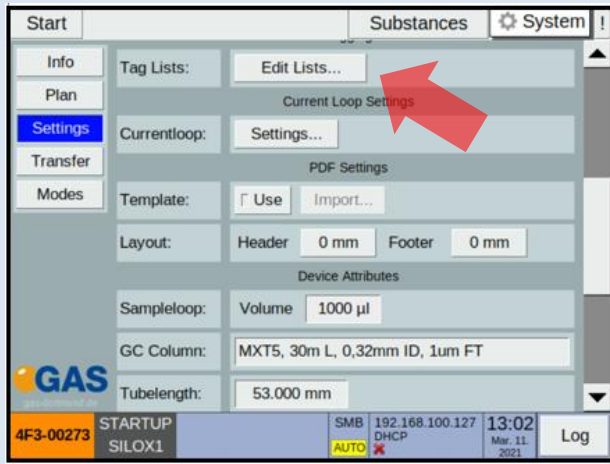

Tag lists can be managed in **System** > **Settings** > **Tag Lists** > **Edit Lists...**

2

Option

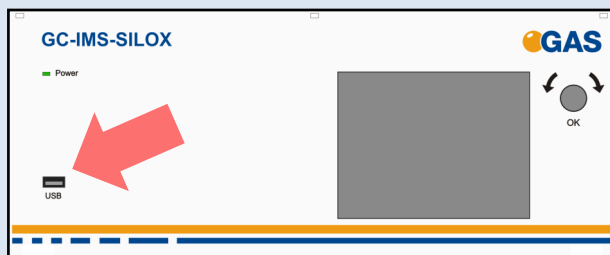

For transfer from USB device:

Connect an USB device (FAT32-formatted) to the **USB** socket at the front side of the housing.

3

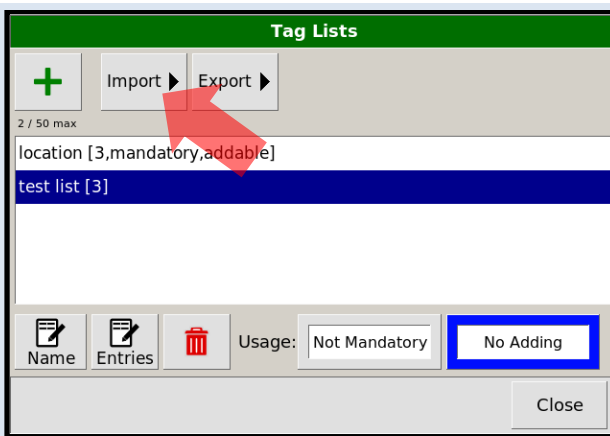

For importing tag lists select **Import**.

See **20 Tag Lists File Formats** for the definitions and file-structures

4

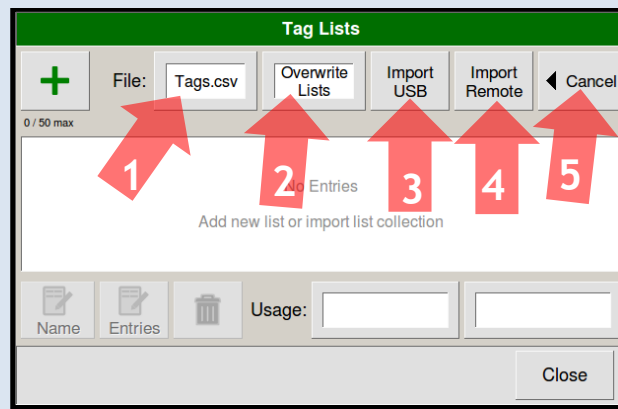

Select the input format and required file name **Tags.csv** or **Tags.json** with **File (1)**.

Select whether existing tag lists should be extended or overwritten with **Overwrite Lists / Extend Lists (2)**.

Start the import process from a connected USB storage device **Import USB (3)**.

or

start the import process from a connected remote server with **Import Remote (4)**.

or

close the import menu with **Cancel (5)**.

5

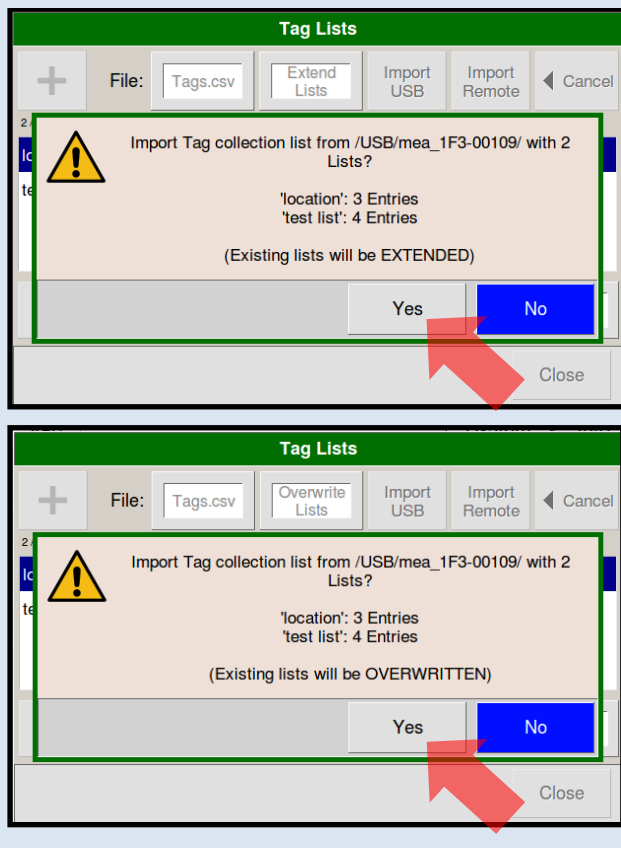

A warning dialog is opened listing the tag lists contained in the file **Tags.csv** or **Tags.json** on the connected USB storage device. Tag lists existing on the device will be **EXTENDED** or **OVERWRITTEN**.

Select **Yes** to proceed.

6

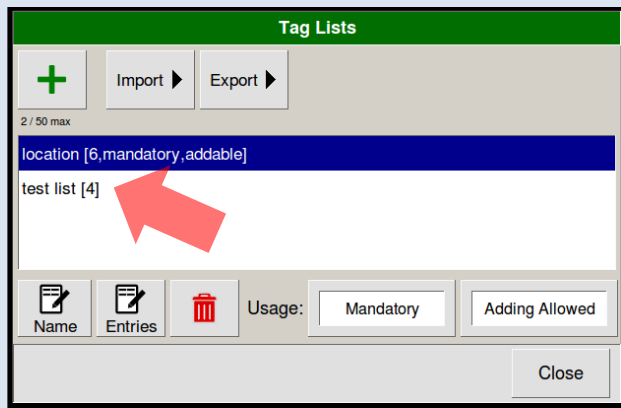

The newly imported, overwritten, or extended tag lists are displayed in the Tag Lists list.

7

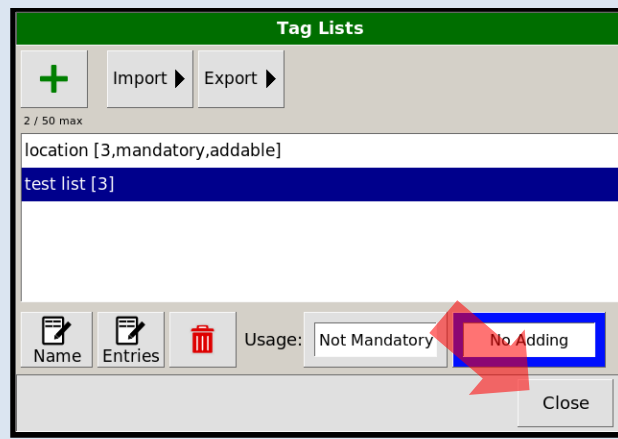

Close the dialog with **Close**.



The import process is completed.

15 Workflow: File Transfer Setup

15.1 Overview

Files can be transferred to and from the device by LAN connection and by USB device connected to the **USB** port at the front of the housing.



A connected USB device is always preferred to a LAN connection when exporting or importing files manually.



The USB device must be formatted to FAT32. Consult your system administrator on formatting USB devices.

Generated measurement files and measurement result files are stored on the internal storage volume of the device.

The following file types are generated from measurements:

File Type	Description
MEA Measurement Files	Contains the complete data of one single measurement including the raw sampling data.
PDF Report Files	Contains a summary of the basic measurement data and the calculated concentrations of one single measurement. See 16 Workflow: PDF Reports - Setup for more information.

CSV Result Files	Contains a summary of the basic measurement data and the calculated concentrations of all measurements on the device.
-------------------------	---

When a connection to a server is established and the export is activated these files are copied to this server when created in the workflow. Measurement files once copied to one of these locations are marked and will be overwritten in case the internal storage is full.

By default, the Service Message Block Protocol (**SMB**) also known as Common Internet File System (CIFS) is used. The Secure File Transfer Protocol (**SFTP**) or a modified version of the Trivial File Transfer Protocol (**TFTP**) can also be used.

LAN file transfer settings can be modified in **System** > **Connections** > **LAN File Transfer** > **Settings...**

Manual transfer and deletion of measurement files stored on the device can be done on **System** > **Results**.

Manual transfer of result report files can be done from the tool bar on **Start** > **RESULTS**.

Manual transfer of tag lists can be done from **System** > **Results** > **Tagging** > **Edit Lists...**

15.2 Connecting to a Server in a LAN

Workflow 10: Connecting to a Server in a LAN



Some PC Ethernet interfaces may not be suited for a direct connection to the device. In that case consider using an Ethernet switch to connect both devices.

1

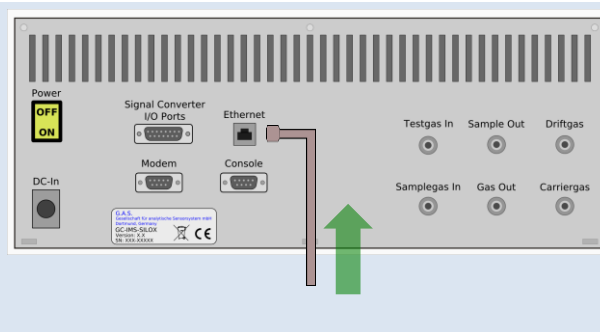

Connect the device with a standard Ethernet cable (LAN cable) to the LAN or directly to a PC.

2

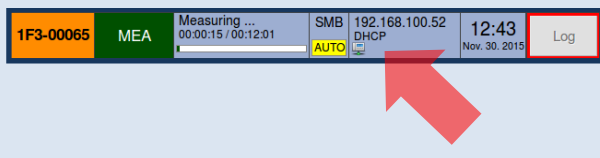

In the status bar the connection icon is displayed.



Make sure that any firewall present in the network does not block necessary traffic. Consult your system administrator on how to configure your firewall.



Consult your system administrator on how to set up a server with one of the protocols **SMB** and **SFTP**. The **TFTP** protocol requires the G.A.S. TFTP Server software to run on a Microsoft® Windows® computer.

3a

Option

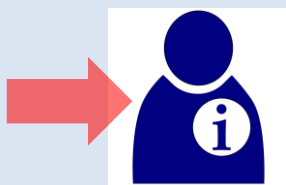

For **SMB** set up a SMB share on a server. Consult your system administrator on how to do that. Watch the G.A.S. tutorial on how to set up file sharing.

3b

Option

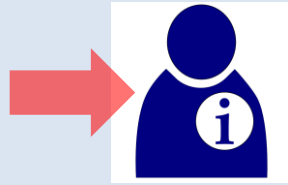

For **SFTP** set up a SFTP server. Consult your system administrator on how to do that.

For an example SFTP server for Microsoft® Windows® PCs see:

<http://www.coreftp.com/server/>

3c

Option

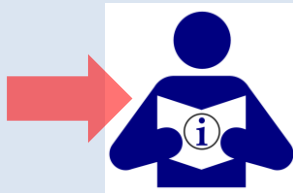

For **TFTP** install the G.A.S. IMS-Control TFTP-Server on the PC. For detailed information see the IMS Software Suite IMScontrol TFTP-Server manual.

4

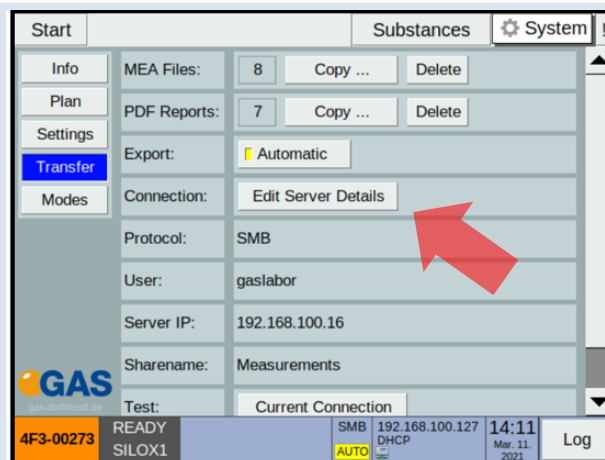

Access **Transfer** for setting file-transfer protocols and options.

Use **System** > **Transfer**

Then **Edit Server Details**

5

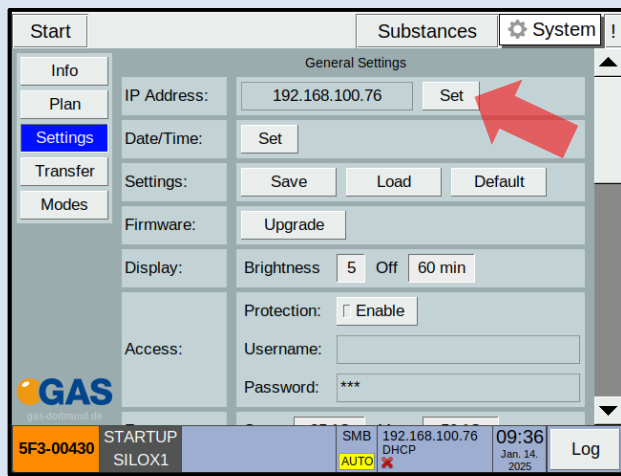

To obtain a DHCP IP address (Recommended for LAN integration of the device):

Use **System** > **Settings** > **IP Address** > **Set**

6

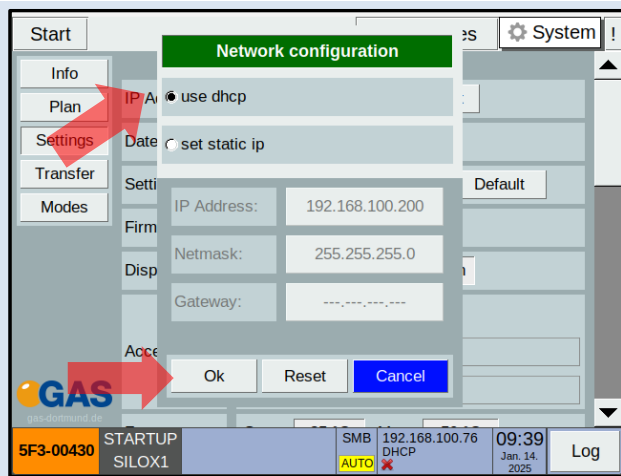

Select **use dhcp** : The device IP address will be assigned by the Network Server.

Click **OK** to confirm.

7

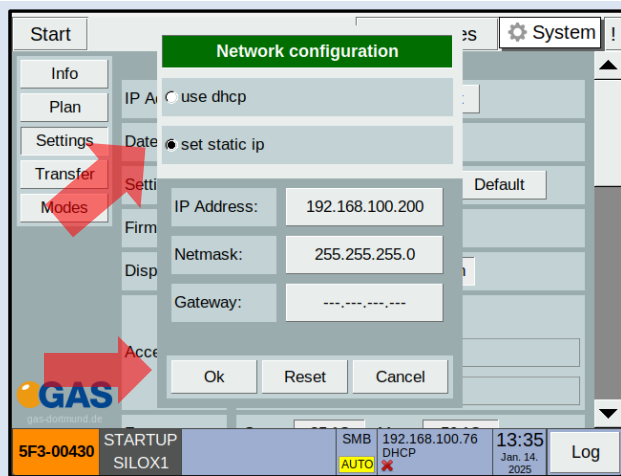

Device IP address, Netmask and Gateway can be entered manually by Network Administrators: Select **set static ip**. Set IP-, Netmask- and optionally Gateway-Address. Enter the desired values in the dialogue box that opens in each case.

Click **OK** to confirm.



Note that both devices must be in the same subnet mask area.
The gateway settings are optional and only necessary for data exchange with another net e.g. Internet.

8

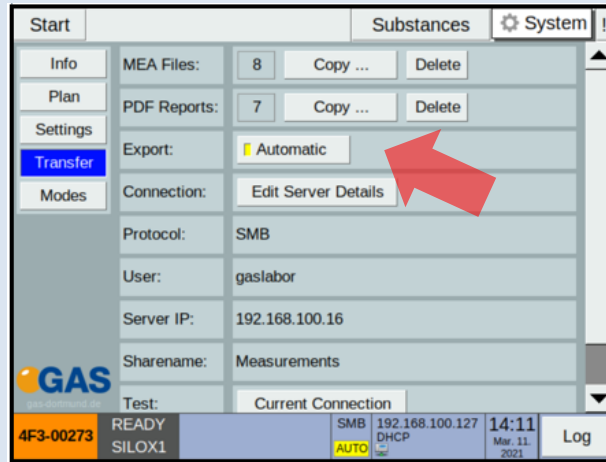

Open **System** > **Transfer** > **Export** to enable or disable the automatic file transfer to a server with **Automatic**

9

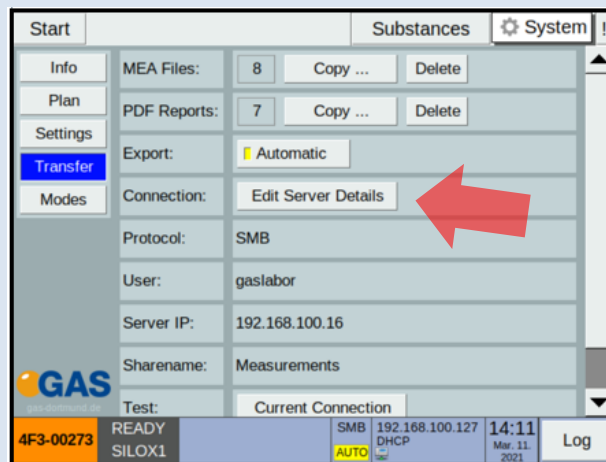

Open **System** > **Transfer** > **Export** to select the required File Transfer Option by clicking the **Edit Server Details** function.

10

The screenshot shows the 'LAN File Transfer Settings' dialog box. At the top, there is a green header with the title. Below it, a checkbox for 'Automatic Export' is checked. The 'Protocol' section has three radio buttons: 'SMB', 'SFTP' (which is selected and highlighted in blue), and 'TFTP'. Below the protocol selection, there are input fields for 'User' (containing 'gaslabor'), 'Password' (masked with dots), 'Server IP Address' (containing '192.168.100.16'), and 'IP Port' (containing '22'). At the bottom, there are three buttons: 'Test Connection', 'OK', and 'Cancel'. A red arrow points to the 'SFTP' radio button.

Select the desired protocol **SMB**, **SFTP** or **TFTP**.

10a
Option

The screenshot shows the 'LAN File Transfer Settings' dialog box. The 'Protocol' section has three radio buttons: 'SMB' (selected and highlighted in blue), 'SFTP', and 'TFTP'. Below, the 'User' field contains 'ims', the 'Password' field is masked with dots, the 'Server IP Address' field contains '192.168.100.1', and the 'Folder' field contains 'Measurements'. The 'Test Connection' button is disabled. At the bottom, there are three buttons: 'Test Connection', 'OK', and 'Cancel' (which is highlighted in blue). A red arrow points to the 'Password' field.

For **SMB** enter **Server IP Address**, **Folder** name, **User** name and **Password** for the SMB share on the server.

Watch the Tutorial on how to set up File Sharing.

10b
Option

The screenshot shows the 'LAN File Transfer Settings' dialog box. The 'Protocol' section has three radio buttons: 'SMB', 'SFTP' (selected and highlighted in blue), and 'TFTP'. Below, the 'User' field contains 'gaslabor', the 'Password' field is masked with dots, the 'Server IP Address' field contains '192.168.100.16', and the 'IP Port' field contains '22'. The 'Test Connection' button is disabled. At the bottom, there are three buttons: 'Test Connection', 'OK', and 'Cancel'. A red arrow points to the 'Password' field.

For **SFTP** enter **Server IP Address**, **IP Port**, **User** name and **Password** for the SFTP server.

10c Option

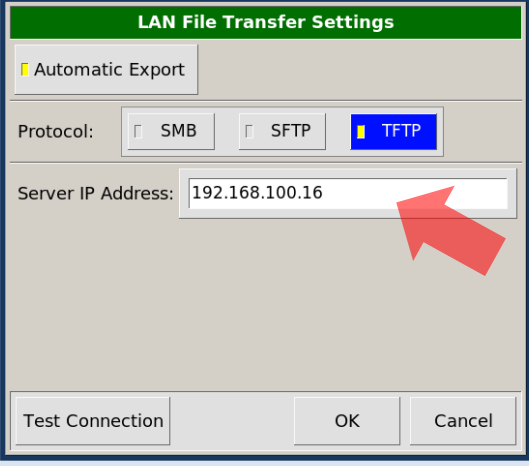

The screenshot shows the 'LAN File Transfer Settings' dialog box. At the top, there is a green header with the title 'LAN File Transfer Settings'. Below the header, there is a section for 'Automatic Export' with a yellow checkmark. The 'Protocol:' section has three radio buttons: 'SMB', 'SFTP', and 'TFTP'. The 'TFTP' radio button is selected and highlighted in blue. Below the protocol section, there is a text field for 'Server IP Address' containing the value '192.168.100.16'. A red arrow points to this text field. At the bottom of the dialog, there are three buttons: 'Test Connection', 'OK', and 'Cancel'.

For **TFTP** enter the **Server IP Address**.

11

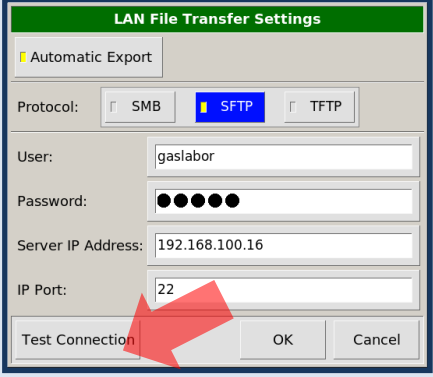

The screenshot shows the 'LAN File Transfer Settings' dialog box. At the top, there is a green header with the title 'LAN File Transfer Settings'. Below the header, there is a section for 'Automatic Export' with a yellow checkmark. The 'Protocol:' section has three radio buttons: 'SMB', 'SFTP', and 'TFTP'. The 'SFTP' radio button is selected and highlighted in blue. Below the protocol section, there are four text fields: 'User' containing 'gaslabor', 'Password' with five black dots, 'Server IP Address' containing '192.168.100.16', and 'IP Port' containing '22'. A red arrow points to the 'Test Connection' button at the bottom left of the dialog. At the bottom of the dialog, there are three buttons: 'Test Connection', 'OK', and 'Cancel'.

After applying changes it is possible to perform a connectivity test by clicking 'Test Connection'.



When the connection cannot be established check the Ethernet cable connection. Mind the network IP address of the server, the used protocol, the name of the shared folder (**SMB**) on the server and the server account login data (**SMB**, **SFTP**). Consult the manuals of your server operating system and your system administrator.

12

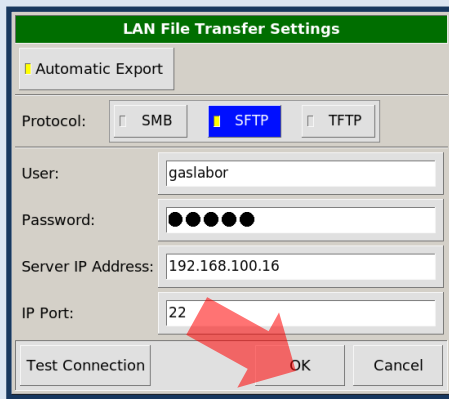

Close dialog with **OK**.

13

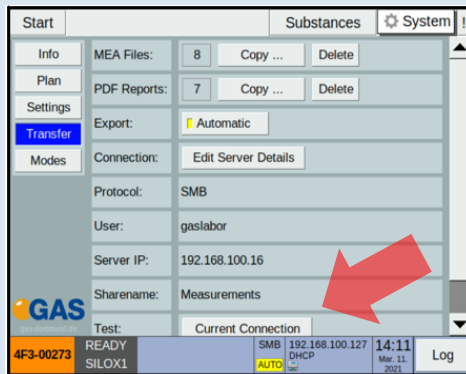

Additionally, it is possible to Use **System** > **Transfer** to view the File Transfer settings and to Test the **Current Connection**

16 Workflow: PDF Reports - Setup and Usage

16.1 Introduction

When a measurement is finished the resulting data is written to files.

- A MEA measurement file is created containing all data including the raw sampling data for this particular measurement.
- The basic data and the calculated concentrations are written to a CSV text file.
- A PDF report file is created containing the basic data and the calculated concentrations for this particular measurement. The PDF file has the same name as the MEA file except for the file name extension.

For creating this PDF file a template file can be loaded into the device. When template usage is activated the report content is printed on this template. It may contain a custom header and footer or a watermark printing.

For more information on importing and exporting files see [15 Workflow: File Transfer Setup](#).

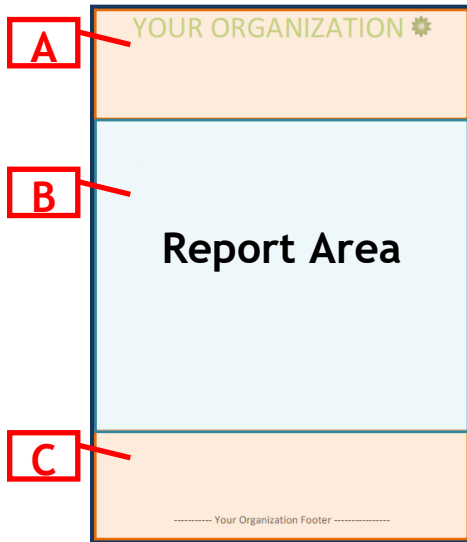

Figure 8: Report Area and Margins

This PDF template file must contain exactly one page that has the DIN A4 format (German DIN 476 - A4 / ISO norm 216 - A4) in the portrait orientation.

The size of the file must not exceed 1 MB.

It can be imported from a connected remote server or from a connected USB device. It must be named **ReportTemplate.pdf**.

To limit the area of the page that is used for the actual report (**B**) a header margin (**A**) and a footer margin (**C**) can be defined. Each can be 0-60 mm wide.

16.2 Workflow

Setup

1

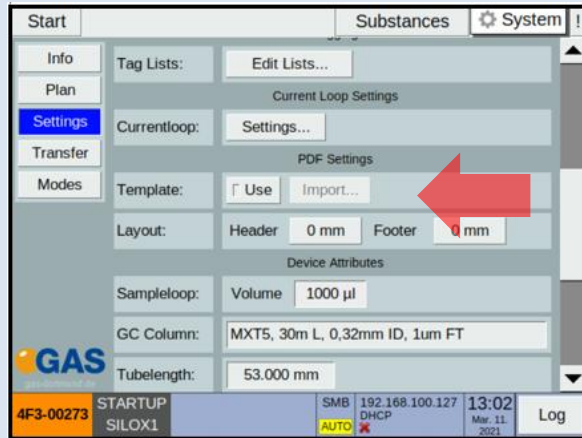

Open page:

System > **Settings** >
Template

2

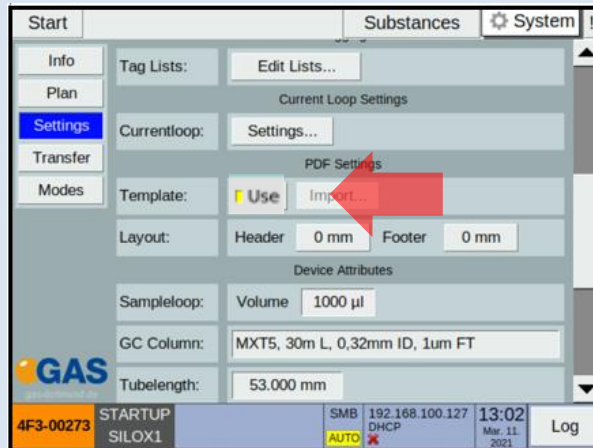

Enable the function **Template** > **Use** to activate the usage of a PDF template file. The actual content of the report is printed onto the template file.

3

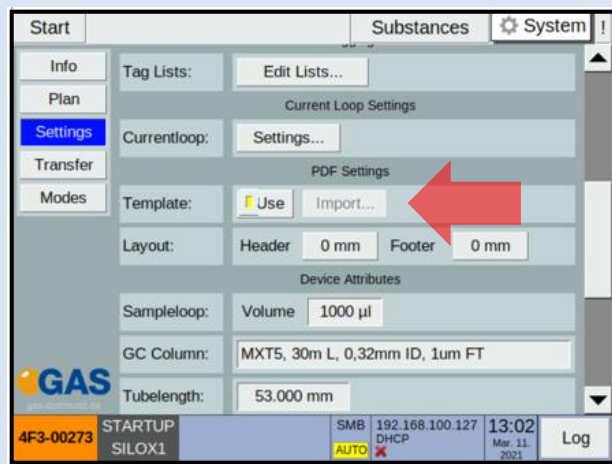

When **PDF Template** > **Use** is activated it is possible to upload with **Template** > **Import...** a PDF template file named

ReportTemplate.pdf

It can be imported from a remote server or from a connected USB device.

4

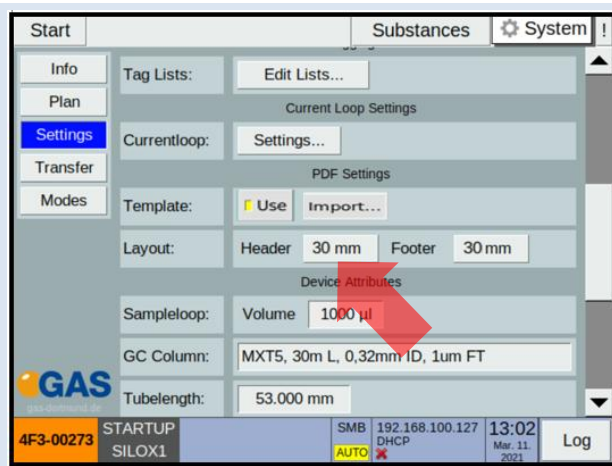

With **PDF Template** > **Header** select the height of the upper margin from the range of 0-60 mm. It defines the upper boundary of the area in which the report content is printed.

5

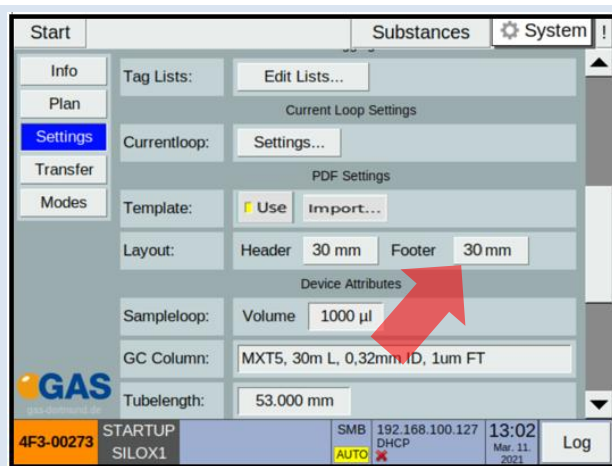

With **PDF Template** > **Footer** select the height of the lower margin from the range of 0-60 mm. It defines the lower boundary of the area in which the report content is printed.

Usage

6

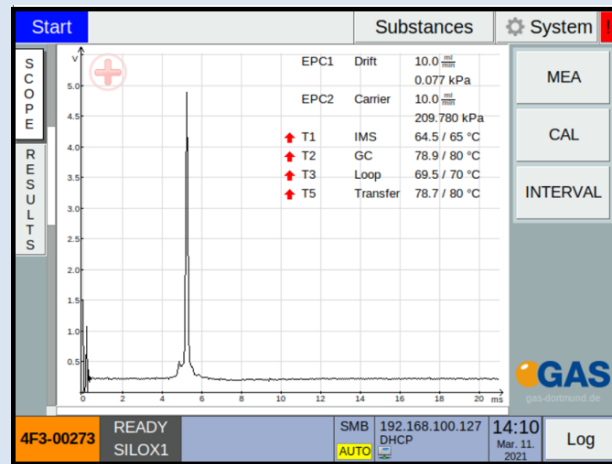

Run a measurement with mode button: **Start** > **MEA** (Or the interval mode with **Start** > **Interval**).

See [10 Workflow: Single Manual Measurement](#) or [12 Workflow Run Automatic Measurements](#) for more information.

7

Option



For transfer to USB device:

Connect an USB device (FAT32-formatted) to the **USB** socket at the front side of the housing.

8

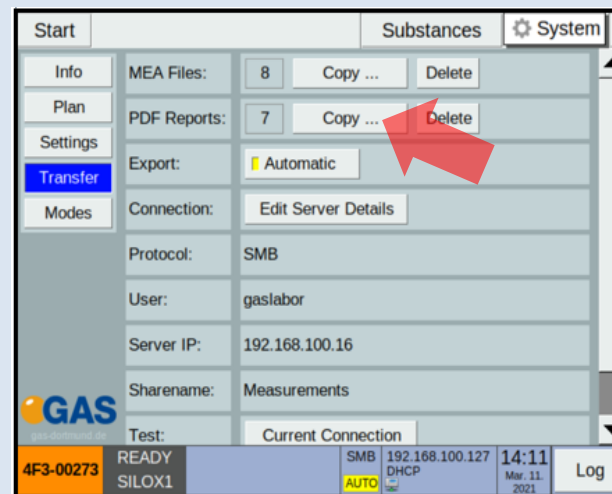

Open page:

System > **Transfer** > **PDF Reports**.

Copy the available PDF Reports to the USB or alternatively to the Remote Server

9

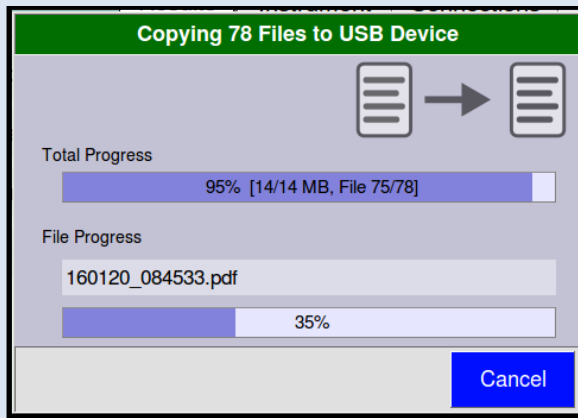

Wait for the copying process to be completed. The dialog will close automatically.

10

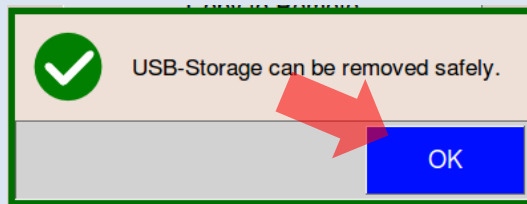

Select **OK** to close message dialog.

17 Workflow: Firmware Upgrade

17.1 Introduction

The firmware of G.A.S. IMS devices can be upgraded by the user with an upgrade file - named `update.gas` - provided by G.A.S.

This file has to be put on an empty USB storage device (e.g. 'USB stick' / 'USB thumb drive') formatted as a `FAT32` file system.



The USB storage device must be formatted to FAT32. Consult your system administrator on formatting USB devices.

17.2 Workflow

Workflow 11: Firmware Upgrade



Do not turn off the device during the upgrade process!

1

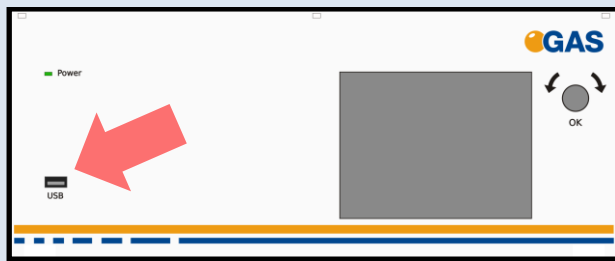

Connect the USB device (**FAT32**-formatted) with the upgrade file - named **update.gas** - provided by G.A.S. to the **USB** socket at the front side of the housing.

2

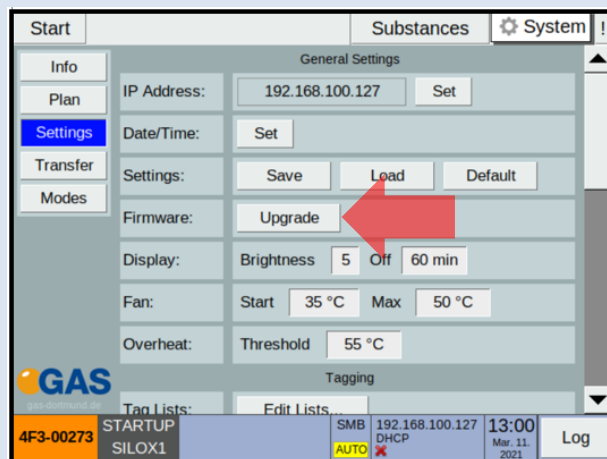

Open page:

System > **Settings** >
Firmware > **Upgrade**.

4

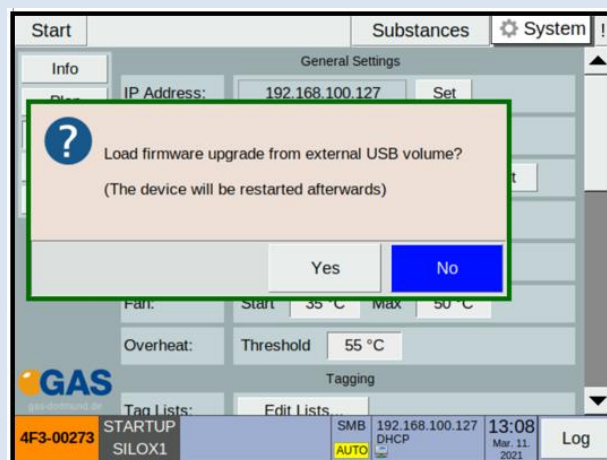

A confirmation dialog opens.

Press **Yes** to start the process.



Do not turn off the device during the upgrade process!

Do not remove the USB device!

The upgrade process will take one minute or more depending on the tasks that are performed during the process.

4



Wait until the process is completed and a system restart dialog opens.

5

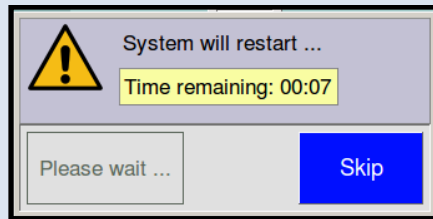

Wait for the device to restart or press **Skip** to restart the device immediately.

6

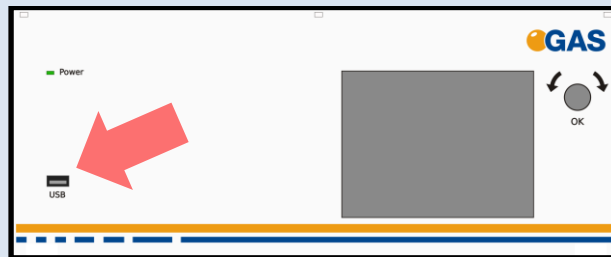

Now:
Remove the connected USB device from the **USB** socket at the front side of the housing.

7



Wait until the device has started and the user interface is visible on the screen.

8

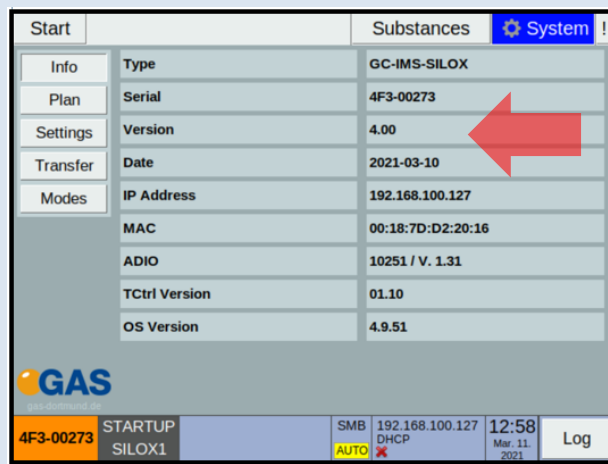

Start	Substances	System !
Info	Type	GC-IMS-SILOX
Plan	Serial	4F3-00273
Settings	Version	4.00
Transfer	Date	2021-03-10
Modes	IP Address	192.168.100.127
	MAC	00:18:7D:D2:20:16
	ADIO	10251 / V. 1.31
	TCtrl Version	01.10
	OS Version	4.9.51

GAS
gas-dortmund.de

4F3-00273	STARTUP SILOX1	SMB DHCP AUTO X	192.168.100.127	12:58 Mar 11, 2021	Log
-----------	-------------------	-----------------------	-----------------	--------------------------	-----

Open page:

System > **Info** > **Version**.

Verify that the new firmware version has been installed.



The device firmware has been upgraded.

18 Workflow: Password Protection

18.1 Introduction

The operating screen can be protected against unauthorised use by means of a password. The user can individually define a user name and password.

The default settings on delivery are:

Username: gas

Password: gas

The password protection can be switched on and off.

18.2 Workflow

Workflow 12: Password Protection



If the user name is forgotten, password protection can be activated via **user name RESET** (in capital letters!) and **password Today's password** (contact GAS support!).

1

The screenshot shows the 'Settings' menu in the GAS control interface. The 'Protection' section is expanded, showing a checkbox labeled 'Enable' which is checked. A red arrow points to this checkbox. Below it, the 'Access' section shows 'Username:' and 'Password:' fields, both currently empty. The 'Fan' section shows 'Start' at 35 °C and 'Max' at 50 °C. The 'Overheat' section shows a 'Threshold' of 55 °C. The bottom status bar displays '5F3-00346 STARTUP SILOX1', 'SMB 192.168.100.76 DHCP AUTO', and the time '15:51 Apr. 06. 2022'.

Set an individual user name.
The default user name on delivery is: **gas**

2

The screenshot shows the 'Settings' menu in the GAS control interface, identical to the previous one. A red arrow points to the 'Password:' field in the 'Access' section, which currently contains three asterisks (***) indicating a masked password.

Set an individual password.
The default user name on delivery is: **gas**

3

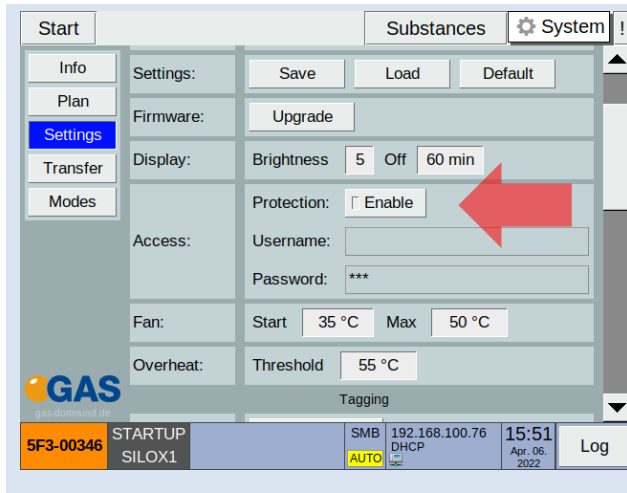

activate the password protection by clicking enable:

System > **Settings** > **Access** > **Protection** > **Enable**

4

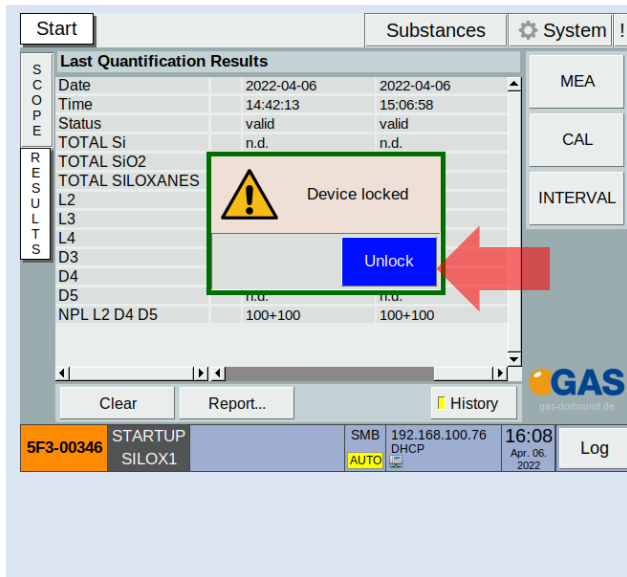

The unit is locked as soon as the screen saver is activated. After that, it only continues to operate after the user name and password have been entered.

To do this, press the **Unlock** button and enter the user name and password in the subsequent dialogues.

19 Graphical User Interface

19.1 Introduction

The graphical user interface of the device can be controlled by using the touchscreen in combination with the pushable rotary knob at the front of the device.

The selected control (button, input field etc.) element is marked blue. To activate it the knob can be pressed.

19.2 Start Page

19.2.1 Overview

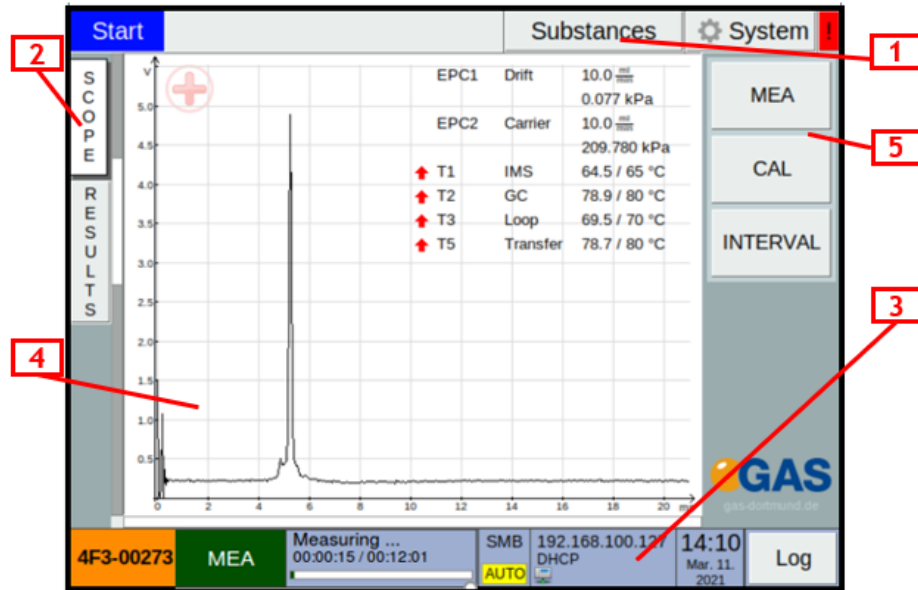

Figure 9: Start Page

Element	Description
1 Page Selection Bar	Buttons for selecting one of the main pages Start , Substances and System . A red blinking Exclamation mark indicates that one or more parameters are differing from their setpoints.
2 View Tab Buttons	Toggleing between the view pages SCOPE and RESULTS .
3 Status Bar	System status information is displayed here.
4 View Area	Displays one of the view pages SCOPE or RESULTS .

5 Action Button Area	<p>Buttons for actions that start and control the measurement process.</p> <p>MEA: Starts a manual measurement.</p> <p>CAL: Starts a manual calibration.</p> <p>INTERVAL: Starts the interval mode.</p> <p>Cancel [Visible when one of the modes is active]: Cancels the active mode and any measurement in progress.</p>
-----------------------------	---

19.2.2 Results View

Displays concentration values that are calculated for measurements.

In the history for a maximum number of 10 measurements values are displayed.

For a maximum number of 2000 measurements values are stored on the device and can be exported into a CSV file on a connected USB device or a remote server. The oldest measurement values are dropped for new ones.

See [5.2 Calculating Concentrations](#) for further information.

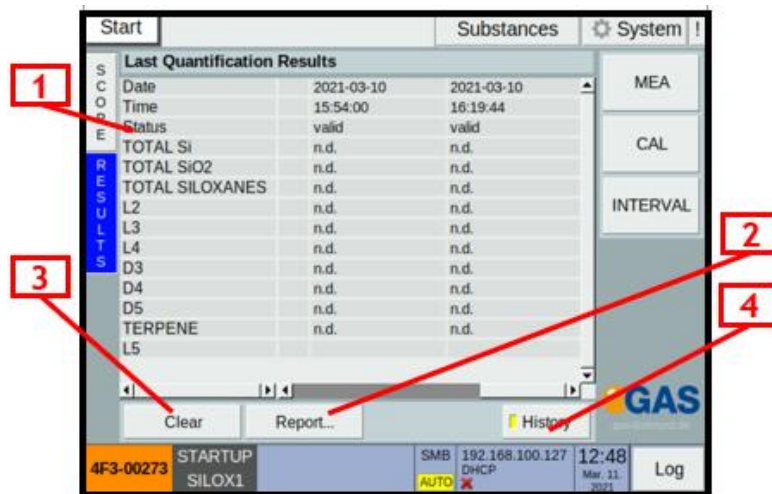

Figure 10: Results View

Element	Description
1 Results List	Displays concentration values of the last measurements and below that the associated tags.
2 Report... Button	Opens a dialog in which the results can be exported to a connected USB device or a remote server.

<p>3 Clear Button</p>	<p>Empties the result list. Deletes all stored result values from the device.</p> <p>Note that measurement data files are not deleted in this process.</p>
<p>4 History Button</p>	<p>Displays or hides the history displaying the recent results.</p>

19.2.3 Scope View

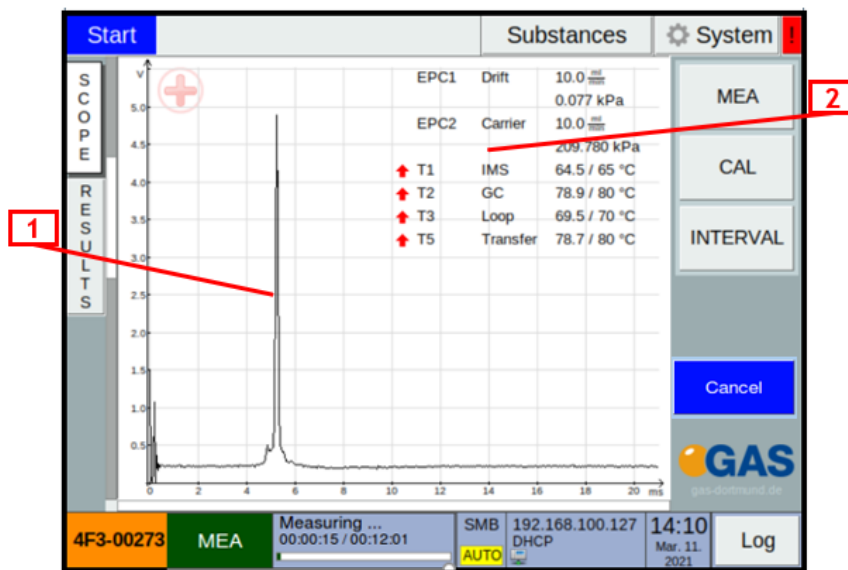

Figure 11: Scope View

Element	Description
<p>1 Spectrum</p>	<p>The current IMS spectrum.</p>
<p>2 Device Parameters</p>	<p>The current temperatures and flows are displayed here. During a measurement the program name is displayed. When temperature or flow set points differ from the current values - e.g. at the beginning of a measurement - they are displayed in red - this would result in an invalid measurement.</p>

19.3 MEA Mode Start Dialog

Element	Description
1 Tag Entry Fields	When Tags are defined the user is asked to select a tag from each defined tag list. If one particular tag list is defined as Mandatory the measurement cannot be started before selecting a tag.
2 Add Tag To List Button	If one particular tag list is defined as Addible this button is displayed. It adds a tag to the list.
3 Clear Button	If the tag list is defined as Not Mandatory this button is displayed. It clears a selected tag.

19.4 Calibration Mode Start Dialog



One or more substance calibrations are modified in the calibration process. Make sure that an appropriate calibration gas supply is connected to the device.

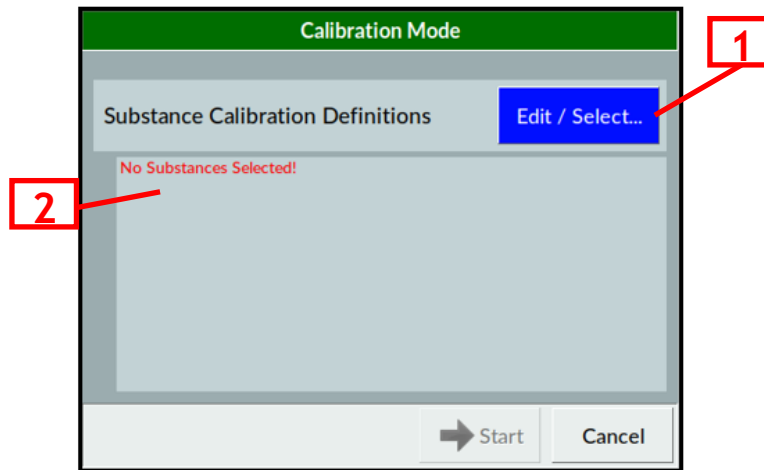

Figure 12: Calibration Mode Start Dialog

Element	Description
1 Edit / Select... Button	Opens the Substance Calibration dialog. One or more substances have to be selected in this dialog. These selected substances will be calibrated during the process.
2 Selected Substances	Substances that will be calibrated. If no substance is selected the calibration cannot be started.

19.5 Substances and the Substance Calibration Dialog



The settings made in this dialog are persistent. They remain in place after the device is turned off and on again or when the next calibration is started.

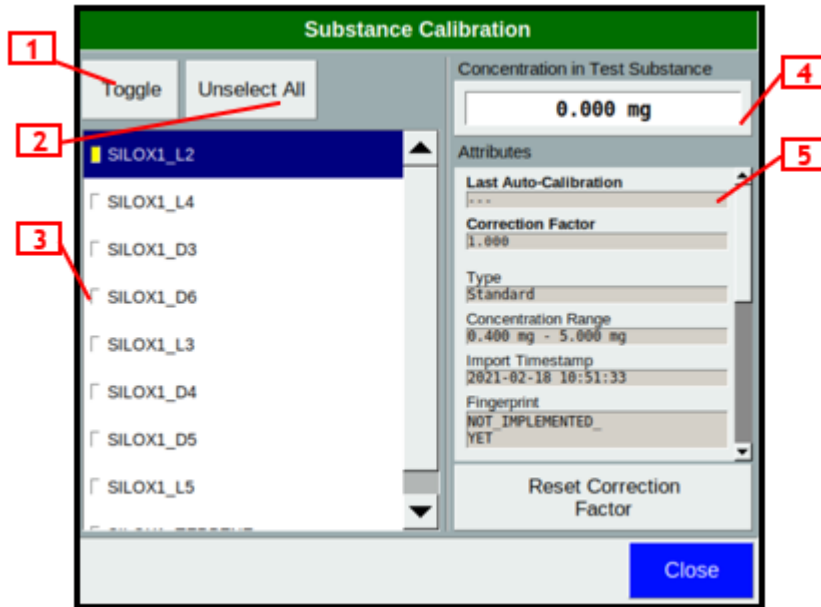

Figure 13: Substance Calibration Dialog

Element	Description
1 Toggle Button	Selects or unselects the selected substance for further processing.
2 Unselect All Button	Unselects all substances.
3 Substances List	List of all single substances. <p>Note that substances like Total Siloxanes that are combined from two or more single substances are not listed here.</p>



<p>4 Test Gas Concentration Field</p>	<p>Concentration of selected substance within calibration gas connected to the device. Must be set by the user before a calibration.</p>
<p>5 Attributes Field</p>	<p>Attributes of the selected substance</p> <p>Last Auto-Calibration: Timestamp of the last automatically triggered calibration when running the system in Interval Mode.</p> <p>Correction Factor: Result of an auto-calibration. 1.0 is the default/contains original calibration values. Can vary in narrow margins.</p> <p>Type: Standard.</p> <p>Concentration Range: Note that this range may differ from the concentration range of the resulting substance concentration. E.g. Total Siloxanes is the sum from various substances that are listed here.</p> <p>Import Timestamp: Date and Time of the import.</p> <p>Fingerprint: Identifier that is added to measurement files to verify the origin of the calibration.</p> <p>Averaging, Intensity Type, Search Ranges, Quantification Model Name, Base Areas:</p> <p>Basic parameters of the selected substance.</p>

19.6 Interval Mode Start Dialog

The screenshot shows the 'Interval Mode' dialog box. It is divided into three main sections: Measurement, Calibration, and Cleaning. Each section has a 'Start Time' field (date and time) and an 'Every' section with input fields for days, hours, and minutes. The Cleaning section also includes 'Cleaning duration' and 'Cooldown duration' fields. At the bottom, there are 'Start' and 'Cancel' buttons. Red callout boxes with numbers 1 through 11 point to specific elements: 1 (Measurement Start Time), 2 (Measurement Start Time time field), 3 (Calibration Start Time), 4 (Measurement frequency minutes), 5 (Calibration Start Time time field), 6 (Calibration frequency minutes), 7 (Cleaning Start Time), 8 (Cleaning Start Time time field), 9 (Cleaning frequency minutes), 10 (Cleaning frequency hours), 11 (Cleaning duration minutes).

Figure 14: Interval Mode Start Dialog

Element	Description
1 Measurement - Start Date and Time	Start time and date of the first measurement.



2 Measurement - Repetition Time	Time span between two measurements.
3 Calibration Button	When deactivated no calibration is performed during the process.
4 Calibration - Start Date and Time	Start time and date of the first calibration in the process. Note that a calibration has priority over a measurement. When a calibration and a measurement collide according to the scheduling, the measurement is skipped.
5 Calibration - Repetition Time	Calibration interval.
6 Edit... Button	Opens the Substance Calibration Dialog. → 19.5 Substances and the Substance Calibration Dialog, Page 109
7 Cleaning Button	When deactivated no Cleaning cycle is performed during the process.
8 Cleaning - Start Date and Time	Start time and date of the first cleaning in the process. Note that a cleaning has priority over a measurement and over calibration. When any of them, calibration or measurement, collide with cleaning according to the scheduling, the measurement and/or calibration are skipped.
9 Cleaning - Repetition Time	Cleaning Interval
10 Cleaning Duration	Duration of the cleaning time
11 Cooldown time	Estimated time required for the instrument to cool-down after a Cleaning

19.7 Date and Time Input Dialogs

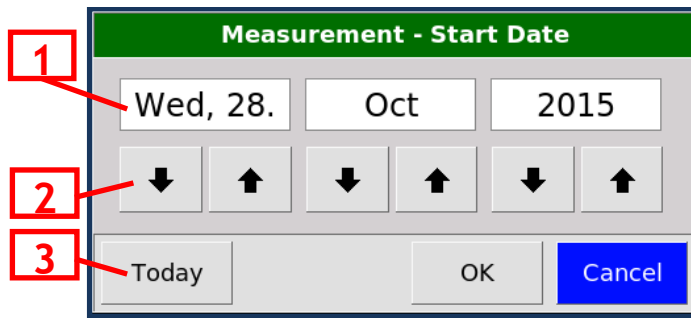

Figure 15: Date Input Dialog

Element	Description
1 Display Fields	Fields displaying day, month and year.
2 Modify Buttons	Buttons for modifying day, month and year.
3 Today Button	Sets the date of today according to the system clock.

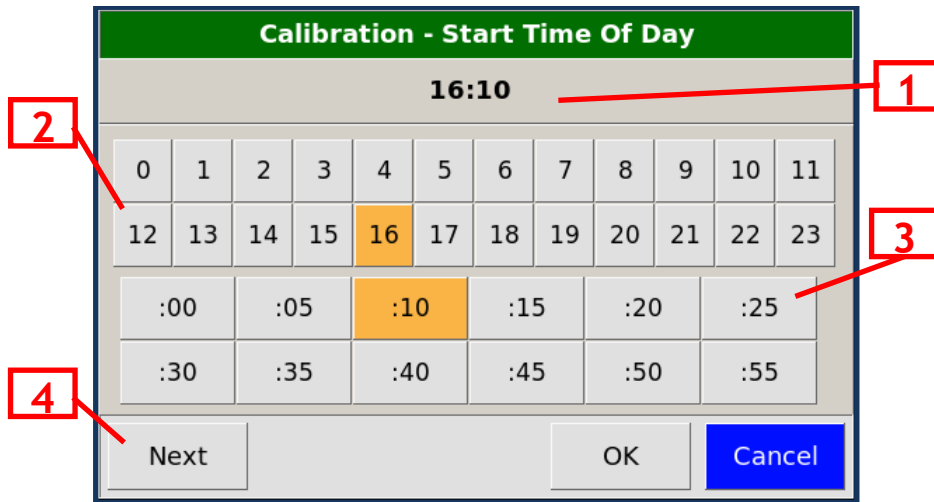

Figure 16: Time Input Dialog

Element	Description
1 Selected Time	The currently selected time.
2 Hour Buttons	Set the hour part of the selected time.
3 Minute Buttons	Set the minute part of the selected time in a 5 minute raster.
4 Next Button	Sets the next possible time according to the current system's clock time.

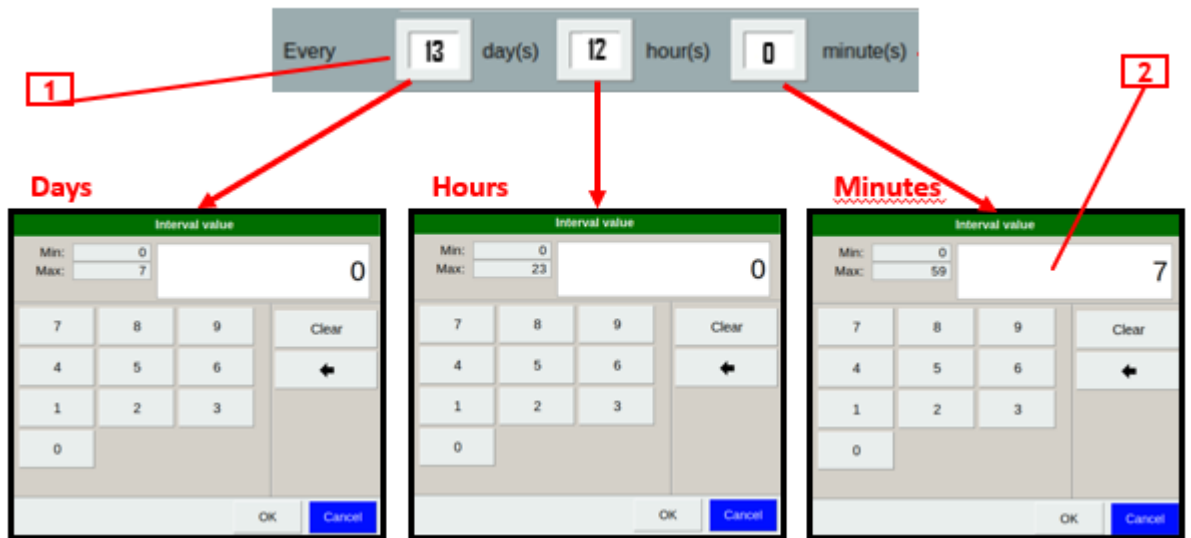

Figure 17: Duration Input Dialog

Element	Description
1 Unit Buttons	Days , Hours , Minutes : Determines the unit of the time duration value.
2 Value	Time duration value in days, hours or minutes. The dialogue boxes have their individual Maxima.

19.8 Status Bar

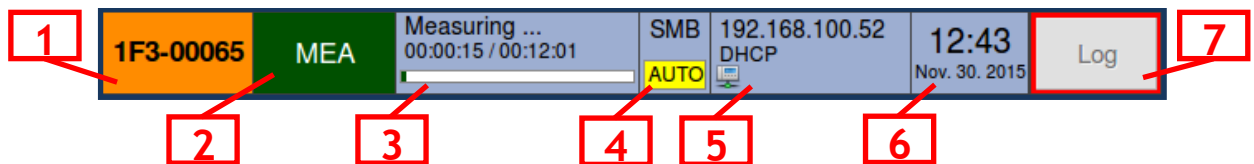

Figure 18: Status Bar

Element	Description
1 Serial Number	Type ID and serial number of the device.
2 State Indicator	<p>The current device status is displayed:</p> <p>STARTUP - Start phase after switching on the device.</p> <p>READY - Default state with reduced gas flows.</p> <p>MEA - A manually started measurement is running.</p> <p>INTERVAL - The interval mode is active.</p> <p>CAL - A manually started calibration is running.</p>
3 Process Info / Progress	Additional information about the current process and its progress are displayed here.
4 File Transfer Mode	The current file transfer protocol is displayed: SMB , SFTP or TFTP . The indicator is yellow when the export is activated, otherwise dark grey.
5 Network Status	The current device IP (if available) and the device IP assignment mode (DHCP / Static) are displayed.
6 Date / Time	<p>The current date and time of the device clock are displayed.</p> <p>See 19.7 Date and Time Input Dialog</p>
7 Log Messages Button	Opens the Log Messages Dialog in which a chronological list of system events is displayed.

19.9 Substances Page

The Substances Page allows to view of the current Substances related Result value range for the active Application Mode:

- Application related calibration ranges,
- Substance definitions and substance individual calibration range
- calibration information (date of import of the calibration, date of last 1-point calibration)

Start		Substances		System !	
Result Value Range		TOTAL Si: 0.0 mg/m ³ - 14.7 mg/m ³			
App Mode		SILOX1			
Σ	TOTAL Si	0.00 - 14.73 mg/m ³			
		Current Loop: Yes			
Σ	TOTAL SiO ₂	0.00 - 31.50 mg/m ³			
Σ	TOTAL SILOXANES	0.00 - 40.00 mg/m ³			
Calib	L2	1.00 - 5.00 mg/m ³			
		Substance Definition: SILOX1_L2			
		Imported: 2021-02-18 10:51:33			
Calib	L3	1.00 - 5.00 mg/m ³			
		Substance Definition: SILOX1_L3			
		Imported: 2016-02-25 09:55:07			
		Substance Definition: SILOX1_L4			
		Imported: 2021-02-18 10:51:33			
Calib	L5	1.00 - 5.00 mg/m ³			
		Substance Definition: SILOX1_L5			
		Imported: 2016-02-25 09:55:07			
Calib	D3	1.00 - 5.00 mg/m ³			
		Substance Definition: SILOX1_D3			
		Imported: 2016-02-26 12:40:05			
Calib	D4	1.00 - 5.00 mg/m ³			
		Substance Definition: SILOX1_D4			
		Imported: 2016-02-25 09:55:07			
Calib	D5	1.00 - 5.00 mg/m ³			
		Substance Definition: SILOX1_D5			
		Imported: 2016-02-25 09:55:07			
Calib	D6	1.00 - 5.00 mg/m ³			
		Substance Definition: SILOX1_D6			
		Imported: 2016-02-25 09:53:25			
Calib	TERPENE	1.00 - 5.00 A.U.			
		Substance Definition: SILOX1_TERPENE			
		Imported: 2021-02-18 10:51:33			
4F3-00273	STARTUP SILOX1	SMB AUTO	192.168.100.127 DHCP	12:57 Mar. 11. 2021	Log

Figure 19: The substance related result value ranges and calibration information

19.10 System Page

The screenshot displays the 'System' page of a device. At the top, there are tabs for 'Start', 'Substances', and 'System' (the active tab). On the left side, there is a vertical menu with five tabs: 'Info', 'Plan', 'Settings', 'Transfer', and 'Modes'. Red boxes with numbers 1 through 5 are placed over these tabs, with red lines pointing to them. The main area shows system details in a table format:

Type	GC-IMS-SILOX
Serial	4F3-00273
Version	4.00
Date	2021-03-10
IP Address	192.168.100.127
MAC	00:18:7D:D2:20:16
ADIO	10251 / V. 1.31
TCtrl Version	01.10
OS Version	4.9.51

At the bottom, there is a status bar with the following information:

4F3-00273	STARTUP SILOX1	SMB 192.168.100.127 DHCP AUTO	12:58 Mar. 11. 2021	Log
-----------	-------------------	--	---------------------------	-----

Figure 20: System Page Default View

Element	Description
1 Info Tab	Allows to access a System information table and retrieve most important System Details.
2 Plan Tab	Contains the Device Plan and indicates the key system elements which can be controlled by the instrument's Firmware.
3 Settings Tab	This Tab allows to view and edit/update all system relevant settings.
4 Transfer Tab	Allows to define the transfer of data, results and reports.
5 Modes Tab	Allows to start different instrument modes

19.10.1 System Page Info Tab

Start	Substances	System
Info	Type	GC-IMS-SILOX
Plan	Serial	4F3-00273
Settings	Version	4.00
Transfer	Date	2021-03-10
Modes	IP Address	192.168.100.127
	MAC	00:18:7D:D2:20:16
	ADIO	10251 / V. 1.31
	TCtrl Version	01.10
	OS Version	4.9.51

1

GAS
gas-dortmund.de

4F3-00273 STARTUP SILOX1 SMB 192.168.100.127 12:59
DHCP AUTO ✘ Mar. 11. 2021 Log

Figure 21: The System Page Info Tab

Element	Description
1 Information Table	Most important System information is summarized in the Info Tab. The table is self-explanatory.

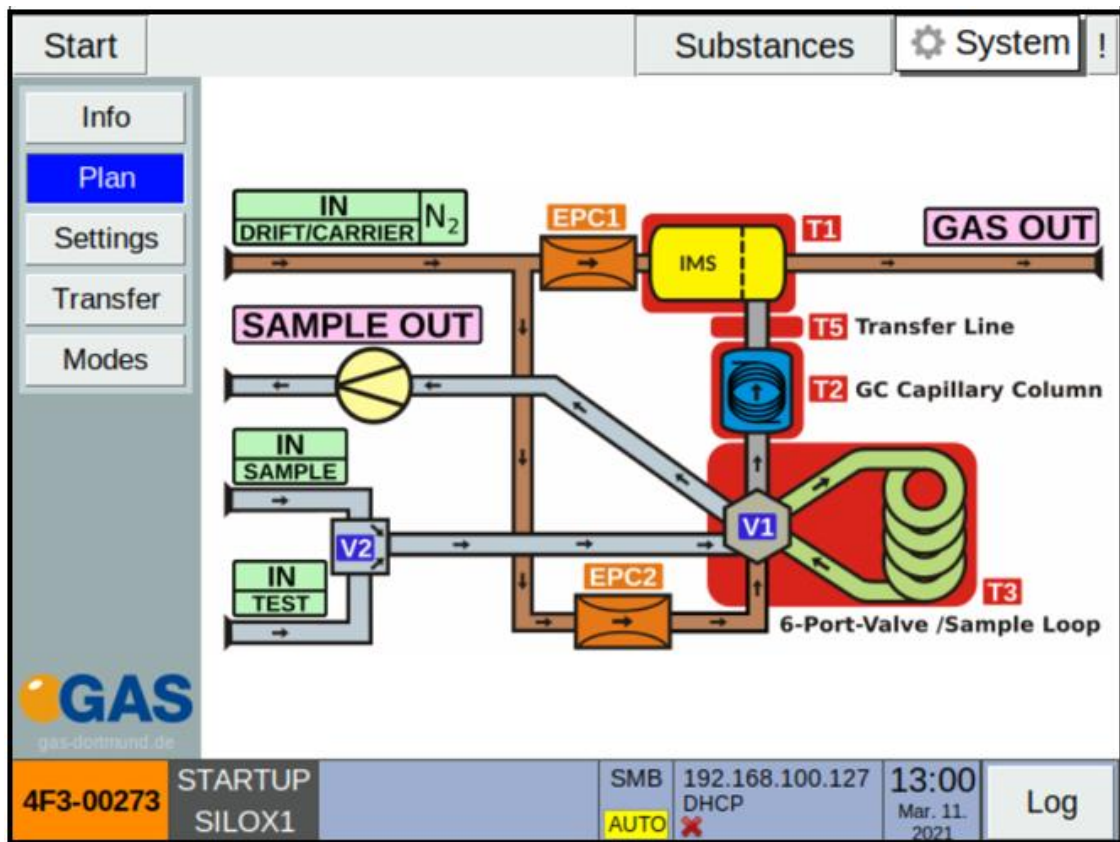

Figure 22: The System Page Plan

The screenshot shows the 'System' settings page with a sidebar on the left containing 'Info', 'Plan', 'Settings', 'Transfer', and 'Modes'. The main content area is divided into several sections:

- General Settings:**
 - IP Address: 192.168.100.127 (1)
 - Date/Time: Set (2)
 - Settings: Save, Load, Default (3)
 - Firmware: Upgrade (4)
 - Display: Brightness 5, Off, 60 min (5)
 - Protection: Enable (6)
 - Access: Username: gas, Password: gas
 - Fan: Start 35 °C, Max 50 °C (7)
 - Overheat: Threshold 55 °C (8)
- Tagging:**
 - Tag Lists: Edit Lists... (9)
- Current Loop Settings:**
 - Currentloop: Settings... (10)
- PDF Settings:**
 - Template: Use, Import... (11)
 - Layout: Header 0 mm, Footer 0 mm (12)
- Device Attributes:**
 - Sampleloop: Volume 1000 µl (13)
 - GC Column: MXT5, 30m L, 0,32mm ID, 1um FT (14)
 - Tubelength: 53.000 mm (15)
 - Drift Volt.: 2132 V (16)
 - Drift Gas: Nitrogen (selected), Air, Other (17)
- Miscellaneous:**
 - Diagnostics: Create and export file (18)
 - Alarm: Frequency 600 Hz (19)
 - Save space: Zip measurements On (20)

The bottom status bar shows: 4F3-00273, STARTUP SILOX1, SMB 192.168.100.127, DHCP AUTO, 13:03 Mar. 11 2021, and a Log button.

Figure 23: The System Page Settings Tab - use the scrollbar to access all setting fields

Element	Description
General Settings	
1 IP Adress	<p>Use Set to open the network configuration window.</p> <p>Choose between use dhcp and set static IP.</p> <p>Under set static IP set the following individual network parameters:</p> <ul style="list-style-type: none"> • IP address • Netmask • Gateway
2 Date / Time	<p>Use Set to access the Date and Time setting dialogue.</p>
3 Settings	<p>Use Save to save/export to USB or Remote of the current Instrument settings/substances/programs.</p> <p>Use Load to import stored Instrument settings/ substances/ programs from USB or Remote .</p> <p>Use Default to Reset the instrument to Factory Default Settings .</p>
4 Firmware	<p>Use Upgrade to load a new Firmware to the instrument.</p>
5 Display	<p>Use the settings for Brightness to increase or decrease the brightness of the display and the Auto-Off time setting.</p>

<p>6 Access</p>	<p>Protect the screen with a password to prevent unauthorised use. Assign an individual password and user name.</p> <p>The default settings on delivery are:</p> <p>Username: gas</p> <p>Password: gas</p>
<p>7 Fan</p>	<p>Use Fan-Start to set the temperature when the Fan ventilation is activated. The Fan Max temperature can be set too.</p>
<p>8 Overheat</p>	<p>Set Threshold to the desired temperature when the instrument sets an Alarm Message.</p>
<p>Tagging</p>	
<p>9 Tag Lists</p>	<p>Use Edit Lists... to manage the Tag Lists.</p> <p>See 14 Workflow: Tag Lists for more information.</p>
<p>10 Current Loop</p>	<p>Use Settings to set the Current Loop parameters.</p> <p>See 13 Workflow: Current Loop Setup for more information.</p>
<p>PDF Settings</p>	
<p>11 PDF Template > Use Button</p>	<p>When activated the imported PDF template file is used to print reports on it.</p> <p>See 16 Workflow: PDF Reports - Setup for more information.</p>

<p>PDF Template > Import... Button</p>	<p>Imports the file ReportTemplate.pdf either from the remote server or from a connected USB device.</p> <p>Must consist of one single page in the DIN A4 format (German DIN 476 - A4 / ISO norm 216 - A4) in the portrait orientation.</p> <p>It may contain your organization header and footer.</p>
<p>12 PDF Template > Header Button</p>	<p>Defines the top margin of the PDF report page. The height can be between 0 mm and 60 mm.</p> <p>Content is only printed below this margin.</p>
<p>PDF Template > Footer Button</p>	<p>Defines the bottom margin of the PDF report page. The height can be between 0 mm and 60 mm.</p> <p>Content is only printed above this margin.</p>
<p>Device Attributes</p>	<p>The Device Attributes will be written in the *.mea file for documentation purpose and also for certain Ion Mobility related calculations in VOCal.</p>
<p>13 Sampleloop</p>	<p>View the Volume of the sampleloop.</p>
<p>14 GC Column</p>	<p>View the GC Column Specification of the GC Column mounted in the Instrument.</p>
<p>15 Tubelength</p>	<p>View the Tubelength of the IMS.</p>

16	Drift Voltage	View the Drift Voltage applied to the IMS.
17	Drift Gas	View the Drift Gas Nitrogen or Air. Note: Drift Gas for landfill and biogas from sewage has to be exclusively Nitrogen for safety reasons (explosive mixture).
Miscellaneous		
18	Diagnostics	Use Create and export file to create a Diagnostics file.
19	Alarm	Set the Alarm Frequency in Hertz.
20	Save Space	Enable or Disable Zip measurements according to the needs .

19.10.4 System Page Transfer Tab

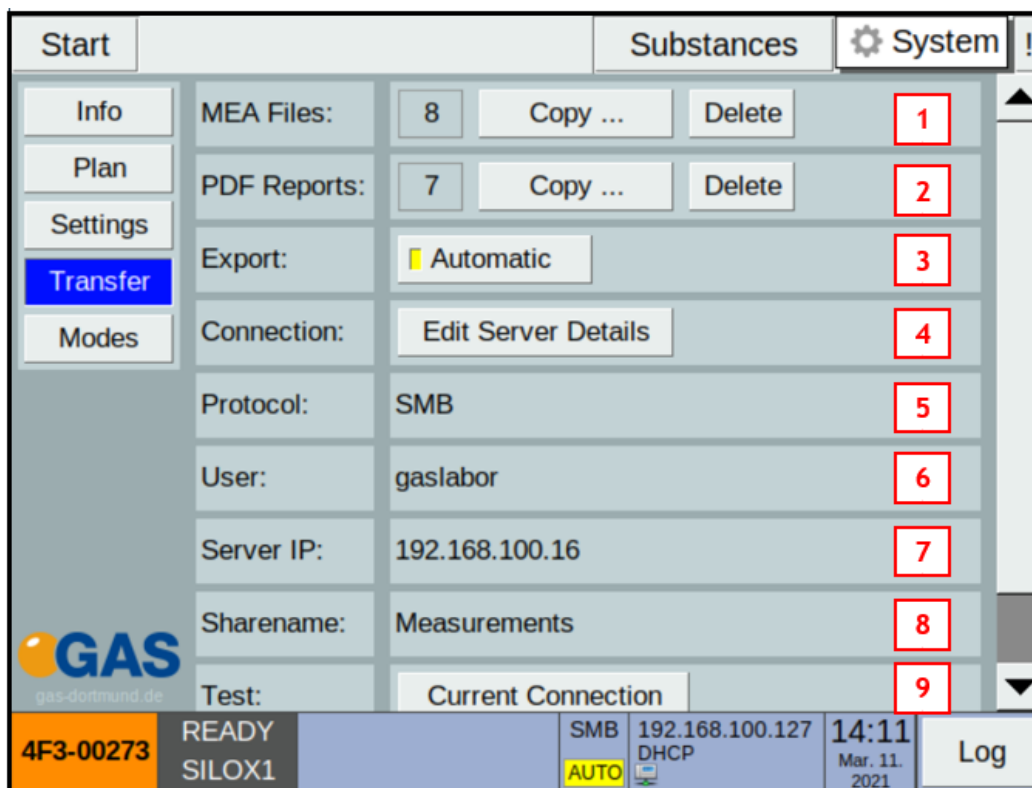

Figure 24: Instrument Tab

Element	Description
1 MEA Files	The number of MEA files is indicated, use Copy ... to transfer the files to the server or Delete stored files.
2 PDF Reports	The number of PDF Reports is indicated, use Copy ... to transfer the files to the server or Delete stored files.
3 Export	Enable or Disable the automatic file export by using the Automatic Button.
4 Connection	Use the Edit Server Details Dialogue Box to enter the required Connection Details. Follow the Workflow 15 File Transfer Setup .

5	Protocol	Indicates the selected File Transfer Protocol, SMB, SFTP and TFTP are supported. Change the Protocol using the Edit Server Details Dialogue Box.
6	User	Indicates the Username for which the Connection is set up. Username and Password can be changed in the Edit Server Details Dialogue Box.
7	Server IP	Indicates the active Server IP Adress. It can be changed in the Edit Server Details Dialogue Box.
8	Sharename	Indicates the name of the shared folder which has to be shared with the indicated User on the Server with the indicated Server IP. It can be changed in the Edit Server Details Dialogue Box.
9	Test	Use the Current Connection Button to start a testing protocol. The status of the active connection will be reported.

19.10.5 The System Page Modes Tab



Figure 25: Connections Tab

Element	Description
1 Cleaning	Select Cleaning Duration and choose between High and Reduced flows . Use the Start Button to start the instrument Cleaning. Find more instructions in the Workflow 7 Using the Cleaning Mode .
2 Standby	Select Standby Duration . Use the Start Button to start the set the instrument to Standby .
3 Active Mode	By Default the Silox1 Application mode is activated which measures the Siloxanes within the defined Silox1 calibration range. Alternative mode is the Silox2 Application mode. By switching the Active mode it will be tested if all required measurement programs are loaded.
4 Labmode	Contact G.A.S.-Support to enter in the protected Labmode with access to all instrument

	functionalities which are required to service the instrument.
--	---

19.11 Current Loop Settings Dialog

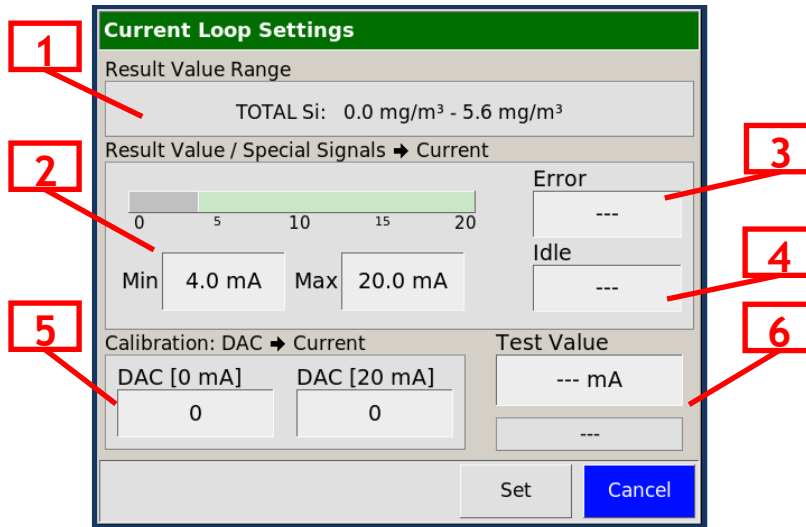

Figure 26: Current Loop Settings Dialog

Element	Description
1 Result Value Range	Displays concentration range of the application mode substance.
2 Result Value → Current	With these controls the concentration range is linearly mapped to a mA-interval within the 0-20 mA-interval.
3 Error Value → Current	Defines a mA value that is set when an error occurred. Can be turned off.
4 Idle Value → Current	Defines a mA value that is set when the device is idle. Can be turned off.

5 DAC -> Current	These two values must be adjusted so the respective output is 0 mA and 20 mA.
6 Test Value Control	Sets an arbitrary mA-test value that is written as output value. Below that the corresponding concentration value is displayed.

19.12 Log Messages Dialog

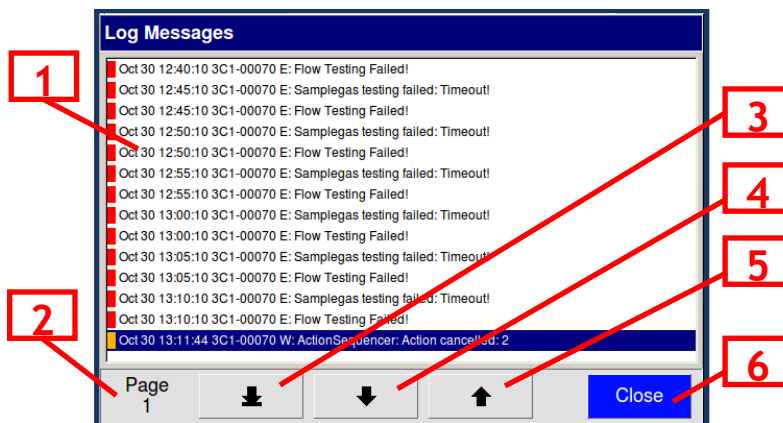

Figure 27: Log Messages Dialog

Element	Description
1 Entry List	A chronological list of system event messages. Warnings are marked orange, error messages are marked red.
2 Page Indicator	The current page number.
3 To Page 1 Button	Scrolls to the first page of the message list.
4 Page Down Button	Scrolls one page down.
5 Page Up Button	Scrolls one page up.
6 Close Button	Closes the dialog.

19.13 IP Address Input Dialog

The IP Address Input Dialog is used to edit the static IP address of the device and the IP address of a remote server. This is necessary when configuring the LAN file transfer. The dialogues for setting the subnet mask and the gateway settings work in the same way.

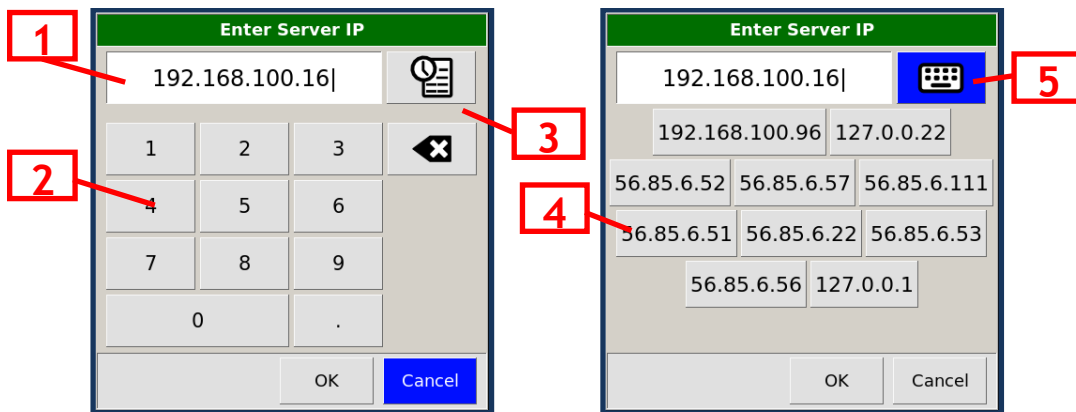

Figure 28: IP Address Edit Dialog

Element	Description
1 IP Address Field	The current IP address.
2 Digit and Dot Buttons / Backspace Button	Use these buttons to enter an IP address.
3 History Button	Displays a menu of previously used IP addresses to choose from.
4 History Entry Buttons	Buttons for entering previously used IP addresses.
5 Keyboard Button	Displays the keyboard.

19.14 Text Input Dialog

The Text Input Dialog is used to enter identifiers, e.g. shared folder name.

Figure 29: Text Input Dialog

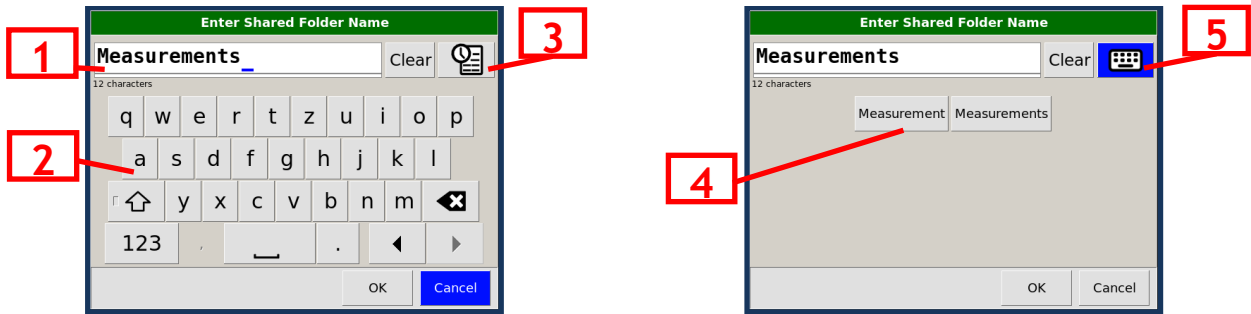

Element	Description
1 Current Text Field	The editable text.
2 Keyboard Buttons	Character and control buttons for entering a text. Depending on the context some buttons are disabled.
3 History Button	Displays a menu of previously used texts to choose from.
4 History Entry Buttons	Buttons for entering previously used texts.
5 Keyboard Button	Displays the keyboard.

19.15 Number Input Dialog

The Number Input Dialog is used to enter number values, e.g. temperature setpoints.

Figure 30: Number Input Dialog

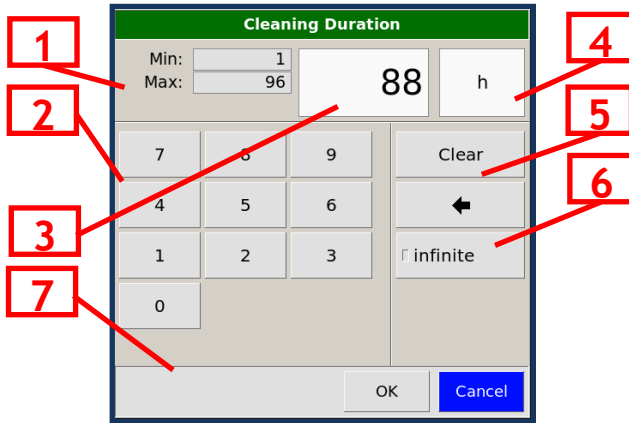

Element	Description
1 Range / Raster Info	Displays the valid value range and the raster (only when raster differs from 1).
2 Keyboard Buttons	Buttons for entering a number.
3 Value Field	The entered numerical or selected special value.
4 Unit	Value unit name.
5 Clear and Backspace Button	Buttons for clearing the input field or deleting the last digit.
6 Dedicated Values Buttons	Dedicated value like Infinite , No Action or Off .
7 Message Field	Displays error messages.

20 Tag Lists File Formats

20.1 Overview

Tag lists can be exported and imported either to/from a simple text file (named `Tags.csv`) compatible with the CSV file format containing only tag list names and tags or to/from a text file in the JSON format (named `Tags.json`) containing all additional flags

Limits to Tag Lists:

- The maximum number of tag lists in the device is 50.
- The maximum number of tags in one single tag list is 500.
- The maximum number of characters in a tag list name is 24.
- Valid characters: upper and lower case letters (without german umlauts, without ß), numbers and spaces
- The maximum number of characters in a tag is 32.
- Valid characters: upper and lower case letters (without german umlauts, without ß), numbers, spaces, special characters: @_ \$%+ - ()! " : ' ; / ? . ,

20.2 CSV Format Specification

The first non-empty line in a Tags.csv file contains the name of the tag list. The following non-empty lines contain the tags of this tag list.

An empty line defines the end of that tag list.

The next non-empty line defines the beginning of the next tag list and its name.

Example of a **Tags.csv** file:

```
1 place
2 position a
3 position b
4 position c
5 position d
6
7 Dortmund
8 Otto-Hahn-Str
9 Saarland Str.
10 Hansaplatz
11 Ostwall
12
13 TaglistName3
14 Tag3-1
15 Tag3-2
16 Tag3-3
17 Tag3-4
```

20.3 JSON Format Specification

When stored in the JSON file format the tag list names and tags are stored along with the flags defining whether or not the list is addible (**FlagAddingAllowed**), whether or not the list must be selected from (**FlagForceInput**).



Attributes that are present in the CSV format as well are marked in orange.

Example of a **Tags.json** file:

```
1  {
2      "Data": [{
3          "Data": ["position a",
4                  "position b",
5                  "position c",
6                  "position d"],
7          "FlagAddingAllowed": false,
8          "FlagForceInput": true,
9          "Name": "place",
10         "ObjectType": "GAS Tag List",
11         "ObjectVersion": "01.00"
12     },
13     {
14         "Data": ["Otto-Hahn-str",
15                 "Saarlandstr.",
16                 "Hansaplatz",
17                 "Ostwall"],
18         "FlagAddingAllowed": false,
19         "FlagForceInput": true,
20         "FlagWhen": "before",
21         "Name": "Dortmund",
22         "ObjectType": "GAS Tag List",
23         "ObjectVersion": "01.00"
24     },
25     {
26         "Data": ["Tag3-1",
27                 "Tag3-2",
28                 "Tag3-3",
29                 "Tag3-4"],
30         "FlagAddingAllowed": false,
31         "FlagForceInput": true,
32         "FlagWhen": "before",
33         "Name": "TaglistName3",
34         "ObjectType": "GAS Tag List",
35         "ObjectVersion": "01.00"
36     }],
37     "ObjectType": "GAS Tag List Collection",
38     "ObjectVersion": "01.00"
39 }
40
```

21 Technical Specifications

21.1 Measurement Ranges

Substance	Measurement Range
Siloxane - L2	Up to 10 mg/m ³ - Standard 0.03 - 2.0mg/ ³
Siloxane - D3	Up to 10 mg/m ³ - Standard 0.03 - 2.0mg/ ³
Siloxane - L3	Up to 10 mg/m ³ - Standard 0.03 - 2.0mg/ ³
Siloxane - D4	Up to 10 mg/m ³ - Standard 0.03 - 2.0mg/ ³
Siloxane - L4	Up to 10 mg/m ³ - Standard 0.03 - 2.0mg/ ³
Siloxane - D5	Up to 10 mg/m ³ - Standard 0.03 - 2.0mg/ ³
Siloxane - L5	Up to 10 mg/m ³ - Standard 0.03 - 2.0mg/ ³
TMSOL	Up to 10 mg/m ³ - Standard 0.03 - 2.0mg/ ³



The actual ranges may differ and/or may be customized to specific requirements. They are displayed in the Substance Calibration Dialog.

→ [19.5 Substances and the Substance Calibration Dialog](#)

21.2 Device

Housing Dimensions	19" compatible Height: 177 mm (4HE) Width: 449 mm (84TE) Depth 435 mm Weight: 15.5 kg
Operating conditions	Temperature range: 0 °C ... +40°C(32...104°F) Humidity: 0-90 % RH, non-condensating
Electrical connectors	2 x RS232 DE9 plug 1 x I/O DA15 socket 1 x Ethernet RJ45 IEEE 802.3 100BASE-T 1 x USB 2.0 Host (USB A Connector) 1 x XLR 3 pole male for Power Supply
Data Processing	Intel Quad-Core processor mSATA 32 GB SSD 2 x RS232/USB/Ethernet/I/O interface
Power Supply	Input line voltage: Grounded AC, 85 - 264 V Input line frequency: 47-63 Hz Input current: < 2.8 A Output voltage: 24 V DC Output current: 9.2A internal Power consumption: < 221 Watt
Cooling	Axial ventilator, temp. controlled, max. 48 m ³ /h
Gas connectors	3 mm stainless steel Swagelok connectors.
Internal Tubing	PTFE
IMS parameters	Drift Tube Length: 53 mm Electrical Field Strength: 500 V/cm Resolution: >50 Operating Temperature: 35-80°C
Ionisation source	Tritium H ³ (β ⁻ radiation)
Data acquisition	Sample Rate: 150 kHz Resolution: 14 bits Trigger Duration: 100 μs Trigger Repetition Rate: 30 ms Transimpedance: 3 V/nA typ.
Drift voltage	~3 kV
Sampling systems	6-way-valve Sample loop Operating Temperature: 35 - 80 °C Temperature Display Accuracy: ± 1 °C Temperature Control Accuracy: ± 0.1 °C

Data storage	Internal storage volume Data transfer via LAN connection via SMB, SFTP or TFTP (G.A.S. variant of TFTP)
Controls	6.4" TFT Touchscreen Pushable rotary knob
Gas chromatographic column	Gaschromatographic capillary column Type: MXT-5 Film Thickness: 1.0 μm Column Length: 30 m ID: 0.32 mm
Column Oven	Operating Temperature: 35 - 80 °C Temperature Display Accuracy: ± 1 °C Temperature Control Accuracy: ± 0.1 °C
Flow Control EPC1 Drift Gas Flow	Type: Differential pressure control Input Pressure 3.0 bar (300 kPa) Output Pressure Stability 0.01% typical Output Pressure Linearity 0.05% typical Operation flow rates: 0 - 500 mL/min
Flow Control EPC2 Carrier Gas Flow	Type: Differential pressure control Input pressure 3.0 bar (300 kPa) Output pressure stability 0.01% typical Output pressure linearity 0.05% typical Operation flow rates: 0 - 150 mL/min
Cleaning mode	IMS, column and sampling system are heated up to > 80 °C (~ 100 °C).

21.3 Current Loop Interface



Output Type	Isolated active current output 0-20 mA
Non-loaded Voltage	< 20 V
Maximum Output Signal	< 22 mA
Maximum Output Load (burden resistance):	500 Ohm
Accuracy	Better than 1 %
Connector Type	D-Sub DA-15 female
Used Pins	Current output: Pin 9 Return: Pin 1 Warning! Do not connect any other pin.

21.4 Consumables

Item
Nitrogen Gas (Purity 5.0 or better)
Calibration Gas (When calibration is desired)

21.5 Ionization Source Specifications



The permission and exemption limits are regulated by the Radiation Protection Ordinance and the European Union Council Directive 2013/59/EURATOM in accordance with the regulations of the International Atomic Energy Authority (IAEA).

Source Type	Tritium H³, Solid-state bonded
Activity	Below the exempt limit of 1 GBq for tritium acc. to, Table B (column 2) of Article 26 of the Directive 2013/59 EURATOM of December 5 th , 2013
Radiation Type	β⁻-Radiation
Radiation Energy	Average energy: 5.68 keV Maximum energy: 18.7 keV
Full Duration Half Maximum (FDHM)	12.3 years
Brake Radiation	2×10^{-7} (mSv / h x GBq) $H_{\text{Brake}} = A \times h_{\text{Br}} \times (1\text{m} / r)^2$ $h_{\text{Br}} = 0.257 \times 10^{-4} \times (E_{\text{Bmax}} / \text{MeV}) \times 2$
Attenuation of Radiation	Air: 4 mm Water: < 100 μm Tissue: < 100 μm Below the exemption limit of a dose rate of 1 μSv/h at a distance of 0.1 m from any accessible surface of the apparatus acc. to Article 26, of the Directive 2013/59 EURATOM of December 5 th , 2013
Mounting Location and Type	Fixed inside the device and not accessible from the outside. The source cannot be accessed directly.

21.6 Modbus TCP Specification

General

Connect the Device using MODBUS TCP on Port 502

Resulttransfer via “ReadHoldingRegister” (FC03)

Register 1 - 125: Current value

Register 127 251: Last value

One Result consists of 125 registers

A Result consists of the Head Area followed by the individual results

Description of Head area

Register	Data Type	Value
1	16 Bit unsigned int	Number of individual results
2	16 Bit unsigned int	Measurement state bitfield
3	32 Bit int (combined with Register 4)	Date and time of measurement encoded in seconds since 1st January 1970. This register contains the least significant two bytes.
4	32 Bit int (combined with Register 3)	Date and time of measurement encoded in seconds since 1st January 1970. This register contains the most significant two bytes.
5		Reserved for future use
6		Reserved for future use

Description of individual result

$n = 7 + (6 * (m - 1))$ in which m = the 1., 2., 3. ...result

Register	Data Type	Description
n	char	4 Ascii Chars (two in this Register two in the following) encoding a short name for the substance
n+1	char	See Register n
n+2	32 Bit int	Concentration of the Substance encoded as 32 Bit integer, this Register contains the two least significant bytes. (Also see Register n+4)
n+3	32 Bit int	Concentration of the Substance encoded as 32 Bit integer, this Register contains the two most significant bytes.
n+4	16 Bit int	A divisor by which the result value has to be divided to compute the actual concentration (usually decimal values of 1, 10 , 100 or 1000 will be found here)
n+5	16 Bit int	Status bitfield

Meaning of status bits for measurements

Bit	Description
0	Everything OK
1	Measurement not valid

Meaning of status bits for individual Results

Value	Description
0	Everything OK
1	Substance concentration is above the upper calibration limit of the device (at least one part of accumulated/calculated substance)
2	Substance concentration is below the lower calibration limit of the device (not detected)
4	The measurement is invalid
8	No calibration for this substance present on this device
>8	Reserved for future use!

Note:

In the rare case that the user switches the Application mode (SiloX1 to SiloX2 or vice versa) - The Result Table shown on the Result Screen may not match with the Result transferred on Modbus TCP

Substance Shortnames

Shortname*	Starting at Register	Substance on device
SILC	7	Total Si
SIO2	13	Total SiO2
SILX	19	Total siloxanes
SXL2	25	L2
SXL3	31	L3
SXL4	37	L4
SXL5	43	L5
SXD3	49	D3
SXD4	55	D4
SXD5	61	D5
SXD6	67	D6
SXTS	73	TMSOL
SXTM	79	TMS

*If a shortname has less than 4 characters, it will be filled with 0x20

Exemplary Readout on Modbus

	Decimal	HEX	Binary	Decoded
1	11	000b	0000000000001011	Number results: 11
2	0	0000	0000000000000000	
3	41149	a0bd	1010000010111101	
4	24479	5f9f	1011111100111111	2020-11-02 06:01:33
5	0	0000	0000000000000000	
6	0	0000	0000000000000000	
7	21321	5349	0101001101001001	SI
8	19523	4c43	100110001000011	LC
9	19	0013	000000000010011	
10	0	0000	0000000000000000	19
11	100	0064	0000000001100100	
12	0	0000	0000000000000000	RES_OK
13	21321	5349	0101001101001001	SI
14	20274	4f32	0100111100110010	O2
15	40	0028	000000000101000	
16	0	0000	0000000000000000	40
17	100	0064	0000000001100100	
18	0	0000	0000000000000000	RES_OK
19	21321	5349	0101001101001001	SI
20	19544	4c58	0100110001011000	LX
21	54	0036	000000000110110	
22	0	0000	0000000000000000	54
23	100	0064	0000000001100100	
24	0	0000	0000000000000000	RES_OK
25	21336	5358	0101001101011000	SX
26	19506	4c32	0100110000110010	L2
27	54	0036	000000000110110	
28	0	0000	0000000000000000	54
29	100	0064	0000000001100100	
30	0	0000	0000000000000000	RES_OK
31	21336	5358	0101001101011000	SX
32	19507	4c33	0100110000110011	L3
33	0	0000	0000000000000000	
34	0	0000	0000000000000000	0
35	100	0064	0000000001100100	
36	2	0002	0000000000000010	RES_NOT_DETECTED

Line	Description
------	-------------

1-6	Head area
1	The Head starts with the Result count, in this case 11.
2	A zero follows.
3,4	Then the date: 14950080066 seconds since 01.01.1970 00:00 .
5,6	Followed by more zeroes (future use).
7-12	First Result
7,8	Substance shortname: Register 7: 0x53 = "S", 0x49 = "I" Register 8: 0x4C = "L" , 0x43 = "C" The concatenated shortname is "SILC".
9,10	Concentration value: First integer 81 Then divisor 100 So the real concentration value is 0.81 with the same unit as indicated on the device.
11,12	Status: Here is 0 so everything went as expected.
13-18	Second Result
	Structured like the first

After the last result the remaining Registers will contain zeroes

Additional State Registers

Register	Data	Type Description
500	32 Bit int (combined with Register 501)	Date and time of measurement encoded in seconds since 1st January 1970. This register contains the least significant two bytes.
501	32 Bit int (combined with Register 500)	Date and time of measurement encoded in seconds since 1st January 1970. This register contains the most significant two bytes.
502	16 Bit int	Firmware Version Major (8 bit), Minor (8 bit), Example: 0x0309 → Version 3.09, 0x040b → Version 4.11

Register 500 und 501 will be updated with every request, so it can be used as a kind of timestampheartbeat.

Internal Software State Register

Register	Data Type	Description
508	32 Bit int (combined with Register 509) Bit 16-31	Not used
509	32 Bit int (combined with Register 508) Bit 0-15	0 : Sequence Running 3 : Procedural Labmode 4 : Interval mode procedural devices 5 : One point recalibration 6 : Measurement 7 : Startup period 8 : Cleaning 11 : High pressure 12 : Low pressure 13 : Program running

Please note: Not all bits are available on GC-IMS-SILOX

Error Registers - High Voltage Errors

Register	Data Type	Description
510	32 Bit int (combined with Register 511) Bit 0-15	0 : ERROR_I2C_CON 6 : ERROR_SOFTWARE_WATCHDOG 7 : ERROR_MISSING_PARAMETER 9 : ERROR_WATCHDOG_RESET 10 : ERROR_INVALID_HARDWARECONFIGURATION 11 : ERROR_EEPROM_CORRUPTED 12 : ERROR_INTERNAL_ERROR 13 : ERROR_OVERVOLTAGE 14 : ERROR_OVERLOAD 15 : ERROR_BROCKEN_WIRE
511	32 Bit int (combined with Register 510) Bit 16-31	Not used

EPC Errors

Register	Data Type	Description
522	32 Bit int (combined with Register 523) Bit 0-15	0 : ERROR_CONNECTION 1 : ERROR_PRESSURE_LOW 2 : ERROR_PRESSURE_HIGH 3 : ERROR_FLOW1_L 4 : ERROR_FLOW1_H 5 : ERROR_FLOW2_L 6 : ERROR_FLOW2_H
523	32 Bit int (combined with Register 522) Bit 16-31	Not used

Temperature Controller Errors

Register	Data Type	Description
524	32 Bit int (combined with Register 525) Bit 0-15	0 : ERROR_TEMP_CON 1 : ERROR_T1_L 2 : ERROR_T2_L 3 : ERROR_T3_L 4 : ERROR_T4_L 5 : ERROR_T5_L 6 : ERROR_T6_L 7 : ERROR_T1_H 8 : ERROR_T2_H 9 : ERROR_T3_H 10 : ERROR_T4_H 11 : ERROR_T5_H 12 : ERROR_T6_H 13 : ERROR_T1_GENERAL 14 : ERROR_T2_GENERAL 15 : ERROR_T3_GENERAL
525	32 Bit int (combined with Register 524) Bit 16-31	16 : ERROR_T4_GENERAL 17 : ERROR_T5_GENERAL 18 : ERROR_T6_GENERAL

Adio Subsystem Errors

Register	Data Type	Description
529	Bit 0-15	0 : ERROR_CONNECTION 1 : ERROR_SOFTWARE_CONNECTION

Storage Subsystem Errors

Register	Data Type	Description
531	Bit 0-15	0 : ERROR_SAVING 1 : ERROR_STORAGE

22 Calculating of silicon 'Total Si' and silica 'Total SiO₂' in GC-IMS-SILOX

Results of individual concentrations ('c') of L2, L3, L4, L5, D3, D4, D5, D6 same as 'Total Siloxanes', 'Total Si' and 'Total SiO₂' are given in mg/m³.

I. Calculation silicon 'Total Si'

Note: The content of silicon (Si) of each siloxane molecule differs and is determined by M = Molecular mass in g/Mol

It is calculated e.g. for hexamethyldisiloxan L2 (C₆ H₁₈ O Si₂)

- ⇒ Molecular mass (L2) = 162.38
- ⇒ Molecular mass (Si) = 28.09
- ⇒ L2 comprises of 2 Si-atomes

Calculation of Si-factor (L2)

$$F(Si) = \frac{2 \times M(Si)}{M(L2)} = \frac{2 \times 28.09}{162.38} = 0.346$$

Calculation of 'Total Si':

Concentration	Factor (Si)
c (L2)	x 0.346
+ c (L3)	x 0.356
+ c (L4)	x 0.362
+ c (L5)	x 0.365
+ c (D3)	x 0.379
+ c (D4)	x 0.379
+ c (D5)	x 0.379
+ c (D6)	x 0.379
	<hr/>
	Σ Total Si

II. Calculation silica 'Total SiO₂'

Note: The content of silica (SiO₂) of each siloxane molecule differs and is determined by

M = Molecular mass in g/Mol

M = Molecular Mass [g/Mol]

⇒ Molecular mass (SiO₂) = 60.08

⇒ Molecular mass (Si) = 28.09

Calculation:

$$F(\text{SiO}_2) = \frac{M(\text{SiO}_2)}{M(\text{Si})} = \frac{60.08}{28.09} = 2.139$$

Calculation of 'Total SiO₂':

Concentration	Factor (Si)	Faktor (SiO ₂)
c (L2)	x 0.346	x 2.139
+ c (L3)	x 0.356	x 2.139
+ c (L4)	x 0.362	x 2.139
+ c (L5)	x 0.365	x 2.139
+ c (D3)	x 0.379	x 2.139
+ c (D4)	x 0.379	x 2.139
+ c (D5)	x 0.379	x 2.139
+ c (D6)	x 0.379	x 2.139
		Σ Total Conc. SiO ₂

Calculation of 'Total Siloxanes':

Note: The content of 'Total Siloxanes' is calculated from the sum of each individual siloxane.

The screenshot displays the 'Last Quantification Result' window. The main table shows the following data:

SCOPE	RESULTS	Value
	Date	2021-03-10
	Time	16:19:44
	Status	valid
	TOTAL Si	1.3 mg/m ³
	TOTAL SiO ₂	2.7 mg/m ³
	TOTAL SILOXANES	3.8 mg/m ³
	L2	0.1 mg/m ³
	L3	1.8 mg/m ³
	L4	0.2 mg/m ³
	L5	n.d.
	D3	0.7 mg/m ³
	D4	0.5 mg/m ³
	D5	0.5 mg/m ³
	D6	n.d.

The status bar at the bottom shows: 4F3-00273, STARTUP SILOX1, SMB AUTO, 192.168.100.127 DHCP, 12:53 Mar. 11 2021, and Log.

Figure 31: Results Window

Table of Figures

Figure 1: Device Plan	19
Figure 2: Flow-chart	20
Figure 3: Front of the Housing	22
Figure 4: Rear of the Housing	23
Figure 5: Device Type/Serial Number Plate	24
Figure 6: Interval Mode	57
Figure 7: Current Loop - Electrical Interface	64
Figure 8: Report Area and Margins	90
Figure 9: Start Page	103
Figure 10: Results View	105
Figure 11: Scope View	106
Figure 12: Calibration Mode Start Dialog	108
Figure 13: Substance Calibration Dialog	109
Figure 14: Interval Mode Start Dialog	111
Figure 15: Date Input Dialog	113
Figure 16: Time Input Dialog	114
Figure 17: Duration Input Dialog	115
Figure 18: Status Bar	115
Figure 19: The substance related result value ranges and calibration information	117
Figure 20: System Page Default View	118
Figure 21: The System Page Info Tab	119
Figure 22: The System Page Plan	120
Figure 23: The System Page Settings Tab - use the scrollbar to access all setting fields	121
Figure 24: Instrument Tab	126
Figure 25: Connections Tab	128
Figure 26: Current Loop Settings Dialog	129
Figure 27: Log Messages Dialog	130
Figure 28: IP Address Edit Dialog	131
Figure 29: Text Input Dialog	132
Figure 30: Number Input Dialog	133
Figure 31: Results Window	153

Table of Workflows

Workflow 1: Unpacking, Placement and Connections	25
Workflow 2: Cleaning Mode.....	40
Workflow 3: Manual Measurement	48
Workflow 4: Manual Calibration	52
Workflow 5: Define the Interval Mode.....	57
Workflow 6: Current Loop Setup	64
Workflow 7: Creating and Editing Tag Lists.....	68
Workflow 8: Exporting Tag Lists	73
Workflow 9: Importing Tag Lists	76
Workflow 10: Connecting to a Server in a LAN	82
Workflow 11: Firmware Upgrade	96
Workflow 12: Password Protection	100

Addendum for GAS Internal use

LABMODE - Short introduction

By Entering the Lab Mode the GC-IMS-SILOX Firmware Enables the full Development Options which usually are hidden from the normal User to make the Graphical User Interface more user-friendly and avoid operational errors.

Support @ G.A.S. Dortmund can provide a Temporary Password

The Labmode should be opened by a G.A.S. trained expert only.

LabMode is used :

- To Edit/view Measurement Programs
- to perform the calibration measurements and manage Substance calibrations
- to modify system settings etc

It is very important to respect the Definitions of the Application-Modes. To run the Silox1 Application Mode it needs a Program Silox1_MEA and a Program Silox1_Cal. Also it is necessary to create the Silox1 related Substance definitions and prepare the calibration models in the required Calibration.gsd file. If any of the required Programs or definitions are missing, a Silox quantification measurement or a Silox Calibration measurement would fail. To warn the user the instrument will switch in a Dummy mode. The following Screenshots shown to give an overview.

Exploring LabMode

1

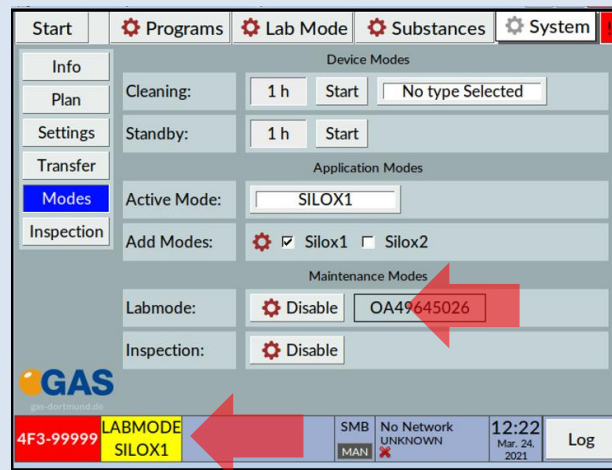

Open page:

System > **Modes** > **Labmode** > **Enable** > **Enter Password**

Within Labmode also the **Inspection** Mode could be accessed (done at GAS Dortmund only)

Enabled Labmode is indicated in the Statusbar

2

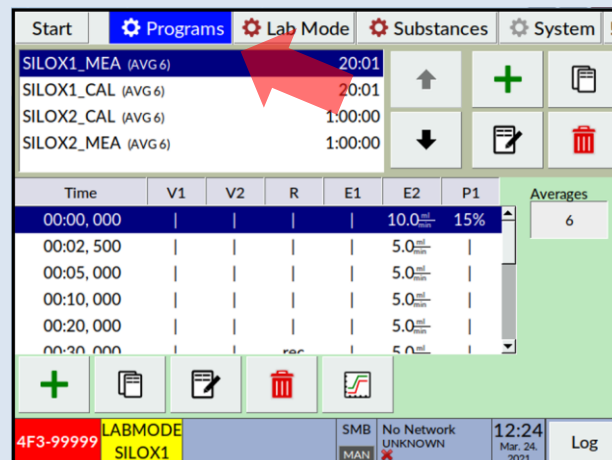

A new page Programs can be accessed. This Page is required to view or edit the available GC-IMS Programs. Consult the GC-IMS User Manual for more Details. Note that for running the Silox 1 or Silox 2 Application the required Programs have to be loaded.

SILOX1_MEA, SILOX1_CAL
SILOX2_MEA, SILOX2_CAL

3

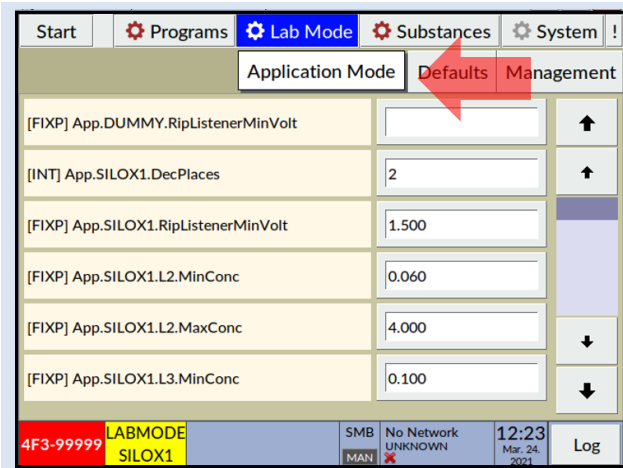

Go To **Lab Mode** > **Application Mode** to view or edit calibration ranges and other parameters

4

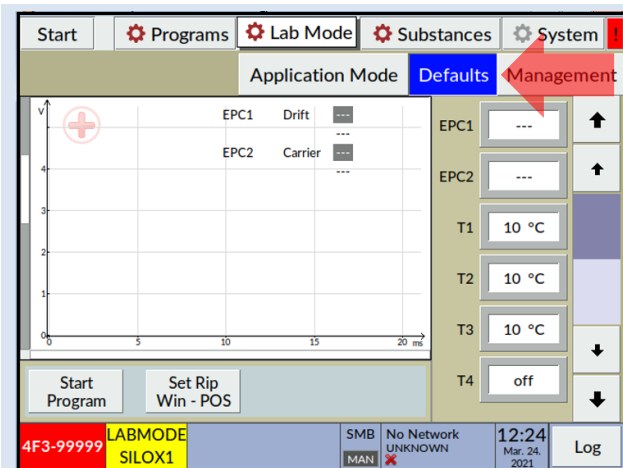

Go to **Lab Mode** > **Defaults** to view or edit the Default settings.

5

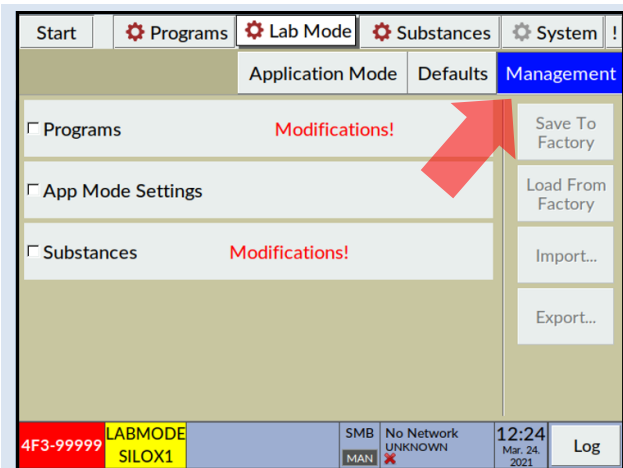

Use **Lab Mode** > **Management** to manage instrument parameters. If changes have been made it is indicated as **Modifications!** If changes applied are incompatible with the required Definitions the instrument will switch to a **Dummy** mode.

It is possible to **load** or **save** to **Factory**, as well as to **load** and **save** settings from **USB / remote**

Manage the Calibration Models

6

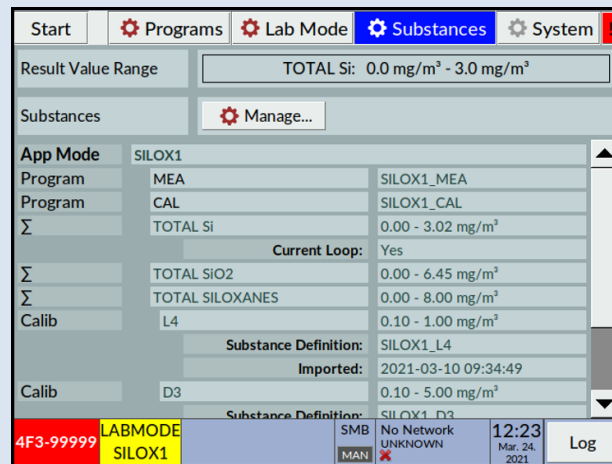

In **Substances** the function **Manage** is enabled

It is possible to import a new calibration.gsd file from USB or Remote and it is possible to edit the Substance definitions - for example also to enable the quantification of Terpenes

Preventing Application Failures due to wrong or missing definitions/programs

7

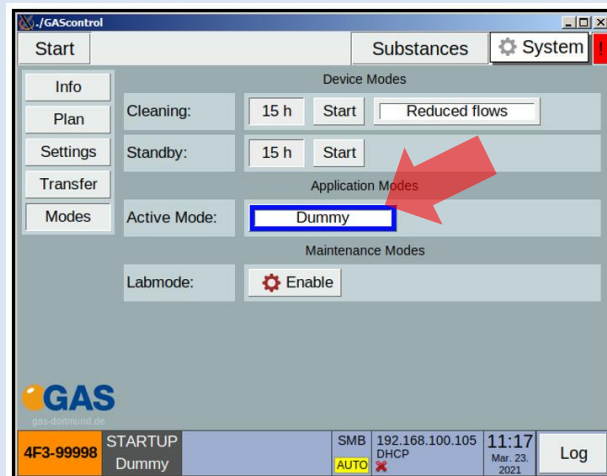

The System page in Modes the Active Mode is displayed as **Dummy** Mode

8

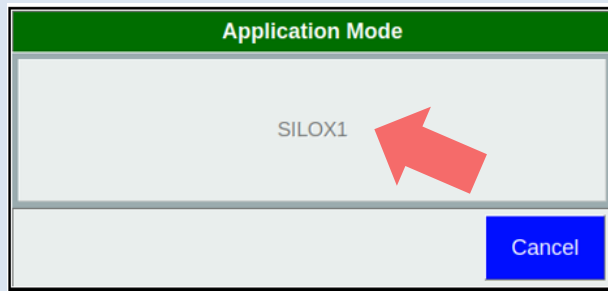

If the Dummy Mode is active no Application Mode can be selected until the Errors are Corrected

9

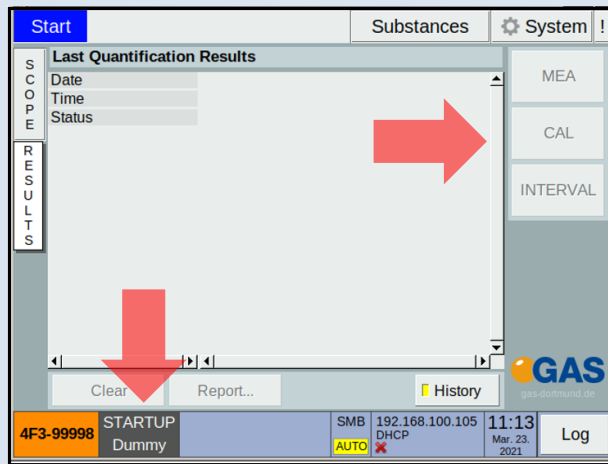

The **Start page** is also changed - it indicates the **Dummy Mode** in the Status bar, also the Start of **Measurements, Calibration and Interval** are disabled.

10

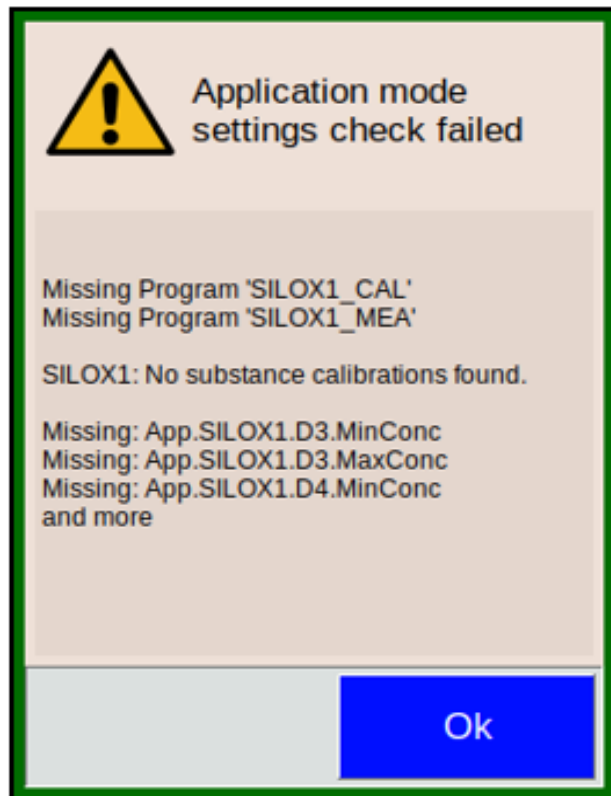

After rebooting the system lists the **Errors**. A potential Fix of the problem could be to import the Factory Settings. For this operation use **Lab Mode** > **Management** to access the **Import** Function which can reload the instrument parameters from the **factory settings**.