



User Manual

Ion-Mobility-Spectrometer

OEM for Agilent 6890/7890 GC-Systems

Version 1.0.4, 05/2019

Ion-Mobility-Spectrometer User Manual

Notice

All data, texts, designs, images and other elements used in this user manual are protected by copyright law. Any infringement may be subject to legal actions.

Passing it on to third parties and producing copies of any kind or form – on the whole or in parts - is not permitted without written agreement by G.A.S. Dortmund Any infringement may be subject to legal actions.

G.A.S. reserves the right to implement technical changes of the product due to improvements without explicitly mentioning them.

CE-Marking according to European Directives EN ISO 17050-1:2004 in accordance with:

- 2006/95/EC The Low Voltage Directive
- 2004/108/EC The Electromagnetic Compatibility Directive.

G.A.S. Gesellschaft für analytische Sensorsysteme mbH

Otto-Hahn-Str. 15

D-44227 Dortmund

Germany

Phone: +49 231/9742-6550

Fax.: +49 231/9742-6555

E-Mail: support@gas-dortmund.de

Internet: www.gas-dortmund.de

Table of Content

1	General Information.....	5
1.1	Information about the Manual.....	5
1.2	Explanation of Symbols.....	5
1.3	Scope of Supply.....	6
1.4	Liability and Guarantee.....	6
1.5	Copyright.....	7
1.6	Return and Disposal.....	7
1.7	Customer Service.....	7
2	Transport, Packing and Storage.....	8
2.1	Inspection after Transport.....	8
2.2	Transport.....	8
2.3	Packing.....	8
2.4	Storage.....	9
3	Cleaning and Maintenance.....	10
3.1	Cleaning.....	10
3.2	Maintenance.....	10
4	Security.....	11
4.1	Intended Use.....	11
4.2	Responsibility of the Operator.....	11
4.3	Requirements of Personnel.....	12
4.4	Dangers.....	13
5	Introduction.....	14
5.1	Setup.....	15
5.2	Housing of the device.....	17
5.2.1	Front Panel.....	17
5.2.2	Rear Panel.....	18
6	Installation Guide.....	19
6.1	Overview: Steps before powering up the instrument.....	19
6.2	Hardware Connections:.....	20
6.3	Prepare Computer: Ion Mobility Spectrometer-Demonstration Software Installation.....	23
7	Ion Mobility Spectrometer Demonstration Software.....	27
7.1	Main Screen.....	27
7.1.1	Basic Window.....	28
7.1.2	Advanced IMS Window.....	30
7.1.3	Settings Window.....	31
7.1.3.1	Storage directory window.....	32
7.1.3.2	Filename template window.....	32
7.1.3.3	Statistics Window.....	34
7.1.4	Info Window.....	35
7.1.5	Monitoring window.....	36
7.1.6	Zooming.....	37
8	System Operation.....	39
8.1	Start operating the Ion Mobility Spectrometer.....	39
8.2	Measurement default values.....	40
8.3	Possible value range.....	40
8.4	General IMS Parameter settings.....	41
8.5	Recording a measurement.....	45
8.6	Remote mode recording.....	46
9	Exemplary workflow.....	47

Ion-Mobility-Spectrometer User Manual

10 Technical data 49

1 General Information

1.1 Information about the Manual

This manual describes a safe and adequate handling of the Ion Mobility Spectrometer (IMS) by G.A.S. as Ion Mobility Spectrometer. Following the instructions of the indicated safety aspects and instructions as well as the national and/or local rules and general safety regulations concerning the prevention of accidents are absolutely imperative.

Before starting the work with the device read the manual completely and thoroughly particularly the chapter *security* and respective safety references. Assure that you/the operator fully understands the terms described.

The manual is part of the device. It has to be stored together with and next to the device at any time.

1.2 Explanation of Symbols

Important and safety-relevant references in this manual are characterized by symbols. These indications which are in-line with industrial safety must be respected and followed at any time.



INFORMATION!

This symbol points at information, which has to be considered for efficient and perfect handling of the equipment.



NOTE! Danger for damage!

This symbol refers to conditions or settings, which can lead to damages, malfunctioning and/or destruction of the device.



DANGER – High Voltage!

This symbol marks references, which can lead to health impairments, injuries, lasting body damages or to death due to electric current.



DANGER - Radioactivity!

This symbol marks paragraphs, which describe potential dangers and damage due to exposure to radioactive radiation.

Ion-Mobility-Spectrometer User Manual

1.3 Scope of Supply

Assure that you have received the full set of supplies. If there is any part missing, please contact the GAS-hotline immediately.

The set of supplied parts consists of:

- Ion Mobility Spectrometer to be connected to a GC-System
- 24V Power supply
- Power supply cable
- Teflon hoses for gas connection
- Ion Mobility Spectrometer - User manual
- Ion Mobility Spectrometer - Technical approval Certificate
- Ion Mobility Spectrometer - Analytical approval
- Transport packaging list
- Ion Mobility Spectrometer Software
- Moisture trap
- GC-System dependent supplies

Optional Accessories

- Big Moisture-Trap
- Notebook to share folders including configuration

1.4 Liability and Guarantee

All data and reference within this manual are compiled under the valid regulations, the state- of-the-art as well as G.A.S. experiences of several years.

The manual has to be stored together with and close to the device at any time and accessible to all persons, who work with it.

This manual must be read carefully before starting to work with the equipment! G.A.S. does not overtake any liability for damage and disturbances, resulting from neglect or ignorance of the manual's instruction.

The graphics in this user manual are schematic and may differ from the actual conditions. The firmware and PC software screen shots in this user manual may slightly differ from the actual conditions.

The scope of supplies might deviate in case of special (customized) equipment, this could cause an inconsistency related to this manual. For questions please contact the G.A.S.-hotline.

G.A.S. reserves the right to implement technical changes of the product based on improvements made without explicitly mentioning them.

1.5 Copyright

The manual is confidential. It is exclusively provided for the staff working with the equipment. All data, texts, designs, pictures and other representations within this manual are protected by the the copyright law and are subject to further commercial patent rights. Each abuse will be prosecuted.

Passing it on to third persons as well as duplications in any kind and form - also in part - as well as the use and/or report of contents are not permitted without written agreement of the manufacturer. Offences lead to payment of damages. We reserve ourselves the right for further legal actions as well as all further rights according to the practice of commercial patent rights.

1.6 Return and Disposal

For a professional redemption, the device or/and its equipment must be returned to the manufacturer or to a third party authorized by the manufacturer!

1.7 Customer Service

For questions concerning the equipment a customer service is available:

G.A.S. Gesellschaft für analytische Sensorsysteme mbH

Otto-Hahn-Straße 15

44227 Dortmund

<http://www.gas-dortmund.de>

Phone: +49 231 / 9742 - 6550

Fax: +49 231 / 9742 - 6555

E-Mail: support@gas-dortmund.de

The telephone hotline is reachable Monday to Friday from 8:00 to 16:00 hours (CET). In urgent cases or if you use fax or e-mail, please also provide your telephone number.

2 Transport, Packing and Storage

2.1 Inspection after Transport

Check the delivered goods immediately after arrival for completeness and/or transport damages. If you detect externally visible transport damage, do not accept the delivery without restrictions. Report the damage on the provided delivery note and/or the transportation documents of the courier company. Submit a complaint. Be aware that claims due to transport damages should be made immediately respecting the the generally valid complaint reporting period (usually 7 days).

2.2 Transport

The equipment should be moved only within the provided packaging. By this precaution, transport damages can be avoided.

2.3 Packing

If no redemption agreement concerning the packing was agreed upon, separate the different materials according to kind and size and supply it to further use or recycling.



Information!

Dispose the packaging material always environmentally friendly and according to the valid local regulations. If necessary, ask a recycling company.

2.4 Storage

Store the device only under the following conditions:

- **Until the use of the equipment keep the provided box locked**
- **Do not store unsecured**
- **Do not store outside**
- **Store only dry and dust free**
- **Avoid mechanical vibrations**
- **Do not expose the device to aggressive media**
- **Protect the device against sun exposure**
- **Storage temperature: 15 to 40 °C**
- **Relative air humidity: max 60%**
- **If you do not use the device, check the storage condition, regularly**
- **Protect against unauthorized access**

3 Cleaning and Maintenance

Natural aging and the covers of certain components of the equipment require a regular cleaning and maintenance.

3.1 Cleaning

Clean the device only with a dry or slightly wet towel.



NOTE! Danger for damage!

Do not use cleaning agents, which contain solvents, acids or bases.

3.2 Maintenance

Maintenance of the device should only be carried out at G.A.S. or through personnel specially trained and authorized by G.A.S. .

4 Security

This section gives an overview of all important safety aspects for an optimal protection of the personnel as well as for the safe and trouble free use of the device. Additionally, the individual chapters contain concrete safety references with respect to the prevention of direct dangers which are indicated by symbols.

4.1 Intended Use

The Ion Mobility Spectrometer is supposed to measure gaseous compounds only.



NOTE! Danger for damage!

Don't introduce any liquid or aggressive compounds into the IMS-device!

The reliability of this device is only ensured when the equipment is applied for its purpose:

The Analysis of Volatile Organic Compounds.



NOTE! Danger for damage!

Each use of the device, that differs from the intended use is forbidden and will be regarded as "out of purpose".

All claims or requirements of any kind against the manufacturer and/or its authorized persons that arise due to damages from a not intended use of the device will be rejected. All damages that arise from a not intended use are of the operator's responsibility.

The intended use of the equipment and its correct handling are described in the chapter operating instructions of this manual. Other parts than the parts belonging to the delivery, may only be used after approval by G.A.S..

4.2 Responsibility of the Operator

The device may only be operated in a perfect technical condition. Before putting the device into operation the condition of the device and its equipment must be checked. The information and instructions provided in this manual have to be followed at any time.

Beside the instructions provided in this manual the local rules for the prevention of

Ion-Mobility-Spectrometer User Manual

accidents, general safety regulations - valid for the area of application of the device - as well as the valid environmental-protection regulations must be considered and respected.

The responsible technicians and operators have to ensure a failure-free use of the device. Responsibilities among the involved persons regarding installation, operation, maintenance and cleaning must be made clear.

4.3 Requirements of Personnel

Only authorized and trained technical personnel may work with the instrument. The operator must get a safety related briefing about all kind of risks and dangers related to the use of the instrument, must be trained to fully understand the operating principle of the instrument and must follow the operating instructions. In addition the operator also must perform his work according to the company's environmental, health and safety policies .

Technical personnel in this context is defined as skilled employees with an analytical technical background to operate high-end and sensitive analytical instruments.

4.4 Dangers

The device and its peripherals were subject of a detailed risk assessment. The device construction and assembly are in line with today's state-of-the-art technology and best practices . The device is reliable in service when operated according to its intended use.



Danger - Radioactivity!

The Ion Mobility Spectrometer device contains a radioactive radiation Tritium source of <500 MBq (which in all EURATOM countries is below the exemption limit). However, do not open the device! Do not try to recover malfunctions of the device! Malfunction recovery, repairs and any maintenance work may only be performed by G.A.S. or by qualified personnel authorized by G.A.S.

Before using the Ion Mobility Spectrometer ensure to connect the gas out to an adequate ventilation system (fumehood).



Danger – Threat to Life or Physical Condition!

The Ion Mobility Spectrometer and its equipment is not certified for the use in areas with explosive gas air mixtures (Zone 0).



Danger – High Voltage!

Electrical Shock Hazard! There are lethal voltages up to 6000 Volts present inside the device housing, especially near the IMS. These voltages may persist also after the power-off of the device.

Use with great care when handling current-carrying parts like the power supply cord. Do not touch current-carrying parts. Do not open the housing while the device is powered-on Do not use damaged parts. Do not disassemble the Ion Mobility Spectrometer and/or the IMS. Do not insert conductive objects into the IMS, the gas connectors or the venting holes!



NOTE! Danger for damage!

When Nitrogen is used as drift gas and helium as carrier gas, ignition of a helium plasma may occur due to the high voltage present in conjunction with a radiation source. This can damage the IMS.

When the housing of the Ion Mobility Spectrometer device is damaged, the device must not be used anymore and must be returned to the G.A.S. by using the original transportation packaging.

5 Introduction

The Ion Mobility Spectrometer by G.A.S. offers diversified use of the technology according to individual application requirements. Besides the advantage of reasonable costs compared to fully equipped IMS instruments, this set-up allows to configure the analytical system around according to customer needs. The module is connected as an external sensor to a standard Gaschromatograph-System.

Samples are ionized by the integrated tritium source with an intensity below the exemption limits according to the International Atomic Energy Authority (IAEA) and EU directive 29/96 EURATOM. Its power input is 24 V DC and a digital USB 2.0 high speed digital interface is used for output.

The Ion Mobility Spectrometer can be operated in negative or positive drift voltage mode. The reactant ion peaks (RIPs) and analyte ion peaks (AIPs) in the positive drift voltage mode will be displayed as maxima in the spectra. In the negative drift voltage mode both will be shown as minima. One of these modes may be more suitable to detect specific substances.

The sample is introduced via the injector port of the Gaschromatograph and its capillary column which is connected through a heated transferline to the Ion Mobility Spectrometer. The Ion Mobility Spectrometer can be heated up to 100 °C. Parameters of the IMS module and the driftgas flow are controlled by an external software by computer



NOTE! Danger for damage!

Under no circumstances any liquid or aggressive compounds may be introduced into the device!

The working reliability is only ensured when the equipment is applied for its purpose:

Analysis of Volatile Organic Compounds.

5.1 Setup

The schematic drawing shows the main gas directions and connections of the Ion Mobility Spectrometer and the possibility to have a connection to a computer which is able to control the device.

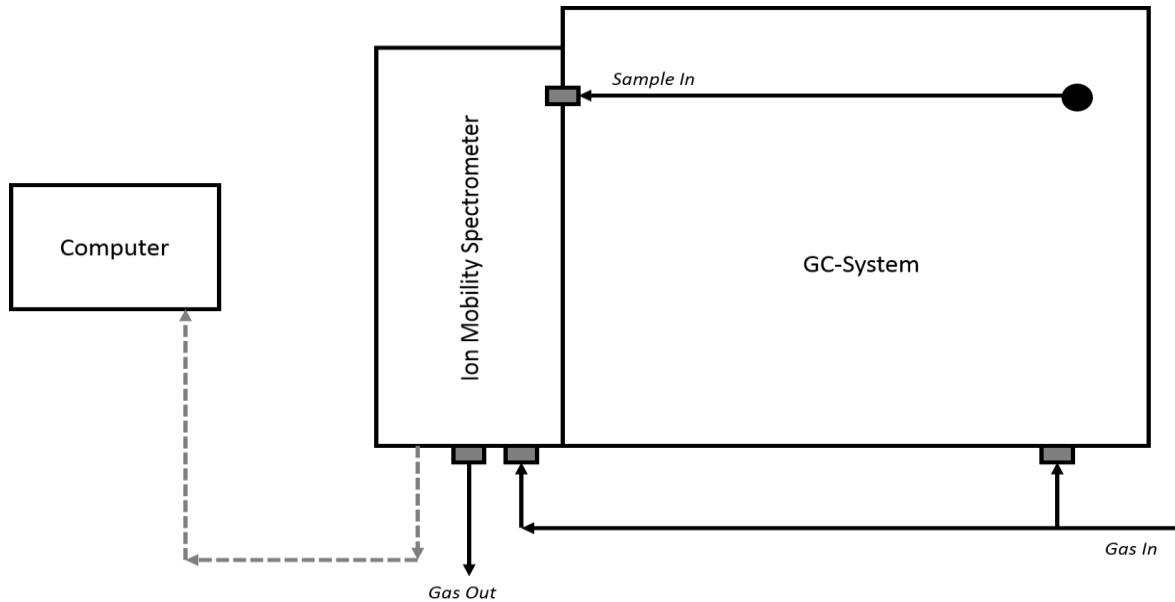

Information!

Inert drift gas / flow reducer (orifice) for nitrogen/synthetic air up to 400 mL/min. Preset over pressure 3 to max. 8 bar. 3 bar over pressure (rel.) leads to requested IMS flow of 150 mL/min. $\pm 10\%$)

The drift gas is introduced into the Ion Mobility Spectrometer (**Gas In port**) by using an internal aperture. (working input pressure: 3 bar = 150 ml/min $\pm 10\%$ gasflow). Please use N₂ or synthetic air only. The gas purity of both must be at least of grade 5.0. If such quality is not available a moisture trap can be used between gas source and Ion Mobility Spectrometer to increase the gas quality.



Information!

The working input pressure of the driftgas must be set to 3 bar , to assure a constant gasflow of about 150 ml/min $\pm 10\%$

Ion-Mobility-Spectrometer User Manual



WARNING

The maximum flow of the driftgas is 400 ml/min. Higher flow will destroy the sensor!

The sample gas is introduced into the Ion Mobility Spectrometer at the **Sample In port with heated transferline** at the side of the housing by using a carrier gas which typically is of the same source as the drift gas. The sample gas is controlled by the coupled GC-System. The consumed drift gas and carrier gas can be vented to the Laboratory ventilation system by connecting an exhaust tube to the Gas Out connector.



NOTE! Danger damage!

Connect the Gas out to an adequate laboratory waste gas ventilation system/fumehood.

5.2 Housing of the device

5.2.1 Front Panel

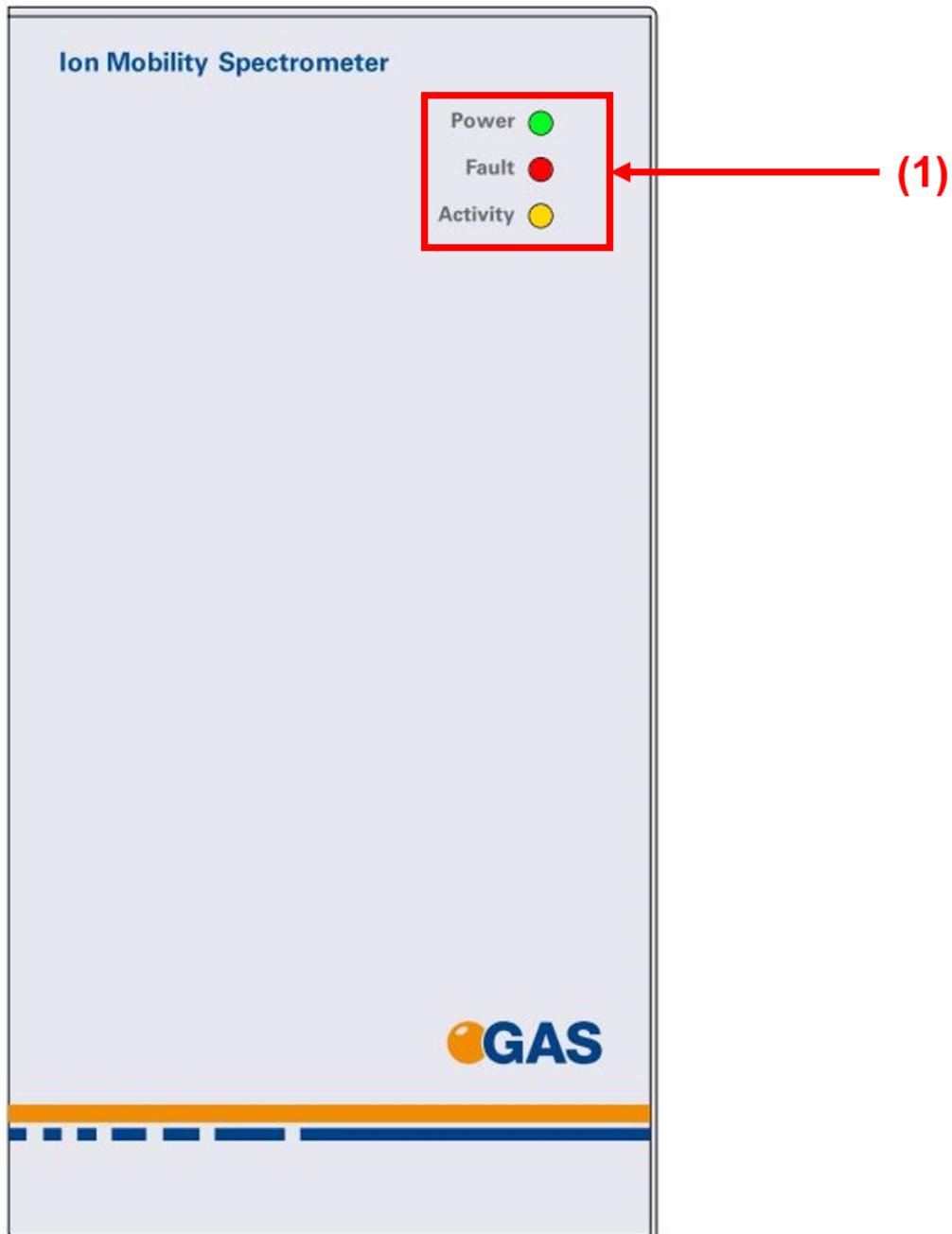

(1) LED

LEDs for Power, Fault and Activity

5.2.2 Rear Panel

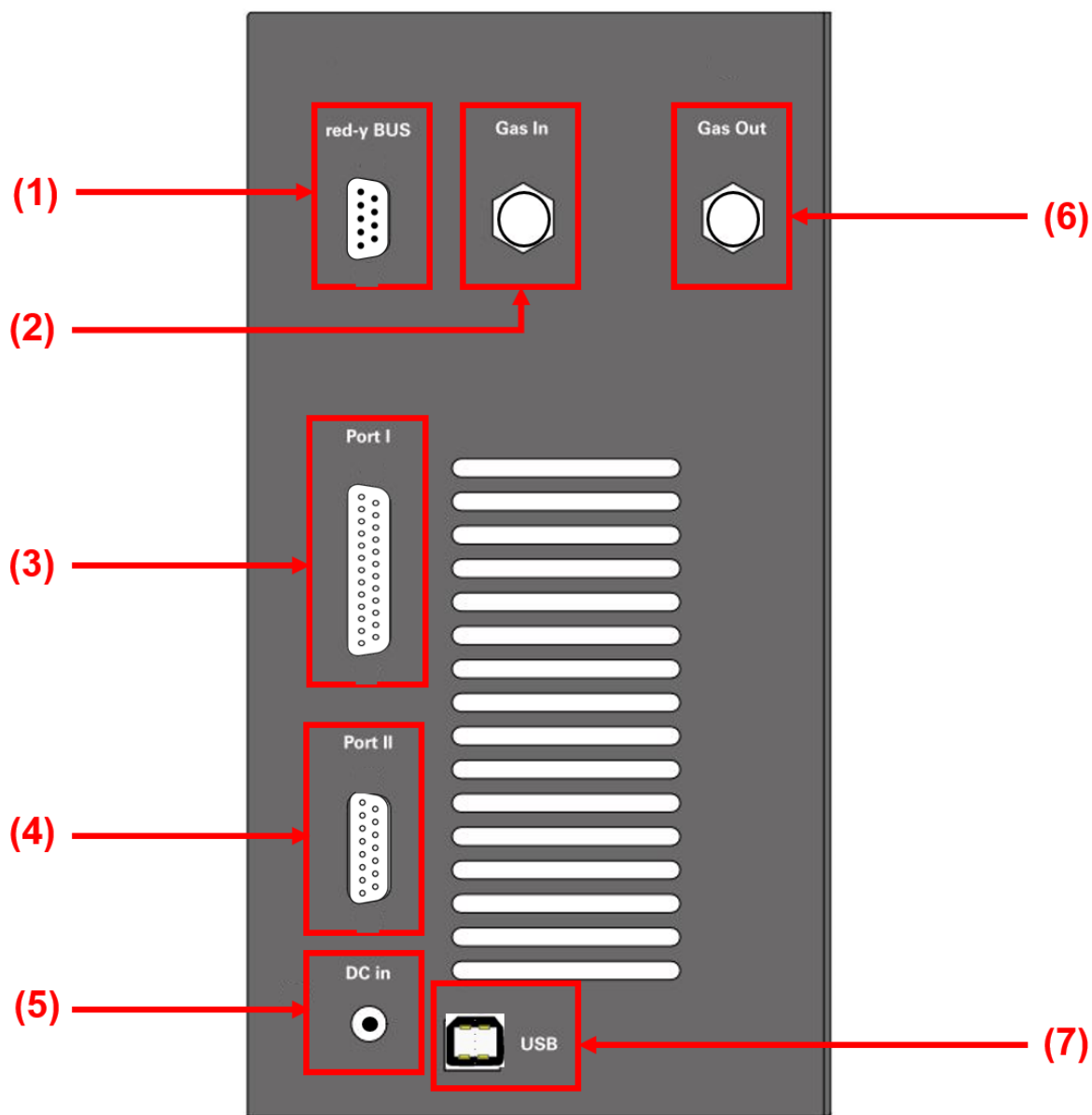

- (1) **Red-y BUS** Connector for a massflow controller. **Optional, not in use at present**
- (2) **Gas In** 3 mm Swagelok inlet plug for connecting the Ion Mobility Spectrometer to a drift gas source.
- (3) **Port I** **Optional, not in use at present.**
- (4) **Port II** Remote connector for communication with a GC control board. **Optional, not in use at present.**
- (5) **DC In** 24V Connector for used to power the Ion Mobility Spectrometer
- (6) **Gas Out** 3 mm Swagelok plug for connecting the OEM-IMS- Module to an adequate laboratory waste gas ventilation system/fumehood.
- (7) **USB** USB Socket for communication with a computer

6 Installation Guide



NOTE! Danger for damage!

A non-reversible modification of the Hardware is required: Agilent Service engineers are trained to make this Hardware modification.

GAS assumes that at this stage the Customer arranges the visit of the responsible Agilent service engineer for the hardware modification.

Please note that the hardware modification of your Agilent GC, namely the installation of an Agilent heated transferline and the mounting of the GC-IMS module has to be done by an Agilent Service Engineer or a Service Engineer which is accredited by Agilent, if an unskilled and unauthorised person implements the GC-Hardware modification Agilent might void the Warranty.

6.1 Overview: Steps before powering up the instrument

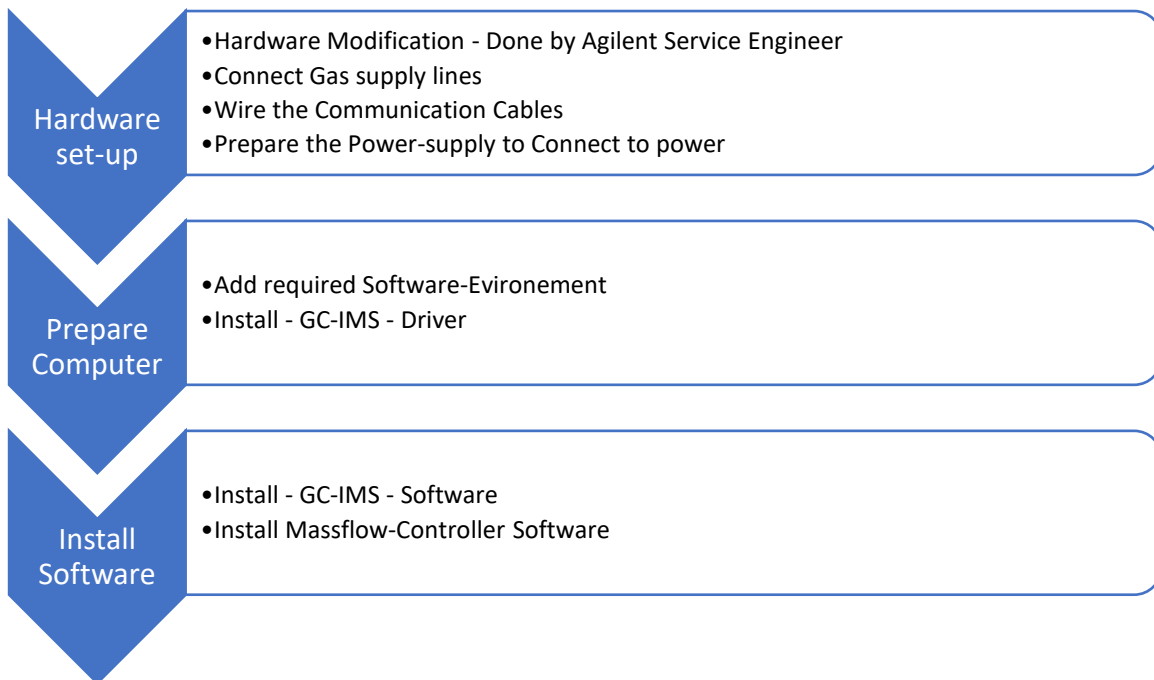

A Quickstart - Guide is also provided as well as an informative presentation on how the Transferline has to be installed

6.2 Hardware Connections:

1.



Connect a waste-tube to the 3 mm Swagelok **Gas-out** connection at the front of the device to an adequate laboratory waste gas ventilation system (fumehood).

2.



Connect the drift gas hose to the 3mm Swagelok **Gas In** connection at the front of the device.

The working input pressure of the driftgas must be set to 3 bar , to assure a constant gasflow of about 150 ml/min \pm 10%

3.

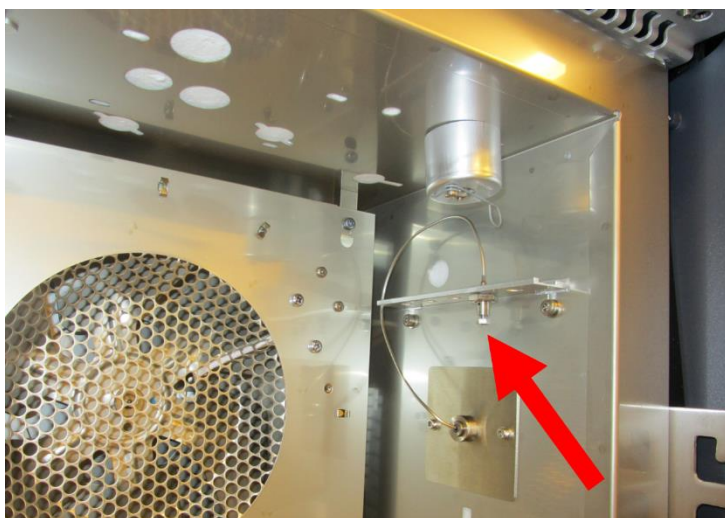

Connect a capillary column to the **Sample In** connection inside the GC-System oven. The installation depth is 4 mm.

This connection option is ready after the GC-hardware modification provided by the Agilent GC-Service engineer. It connects the GC with the IMS sample in port.

4.

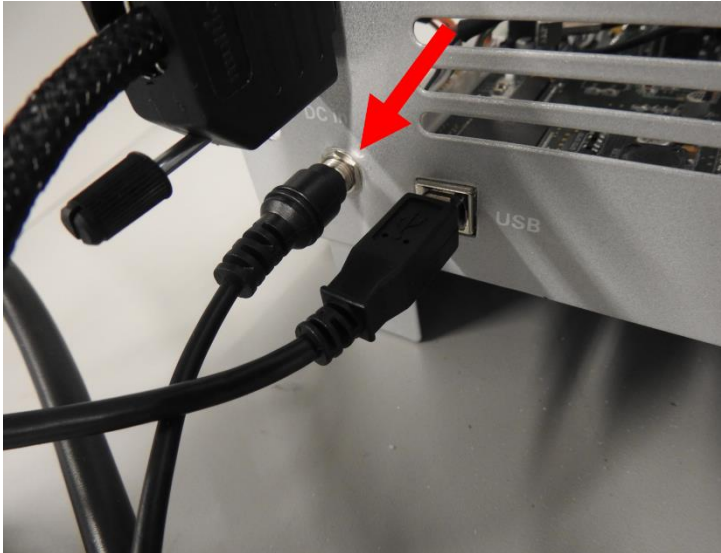

Connect the power supply to the **DC In** connection at the front of the device.

5.

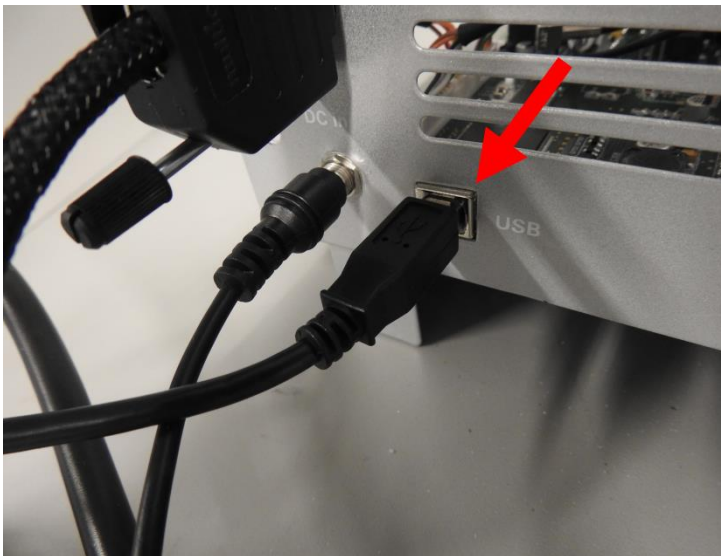

Connect one end of the USB cable to the USB port at the rear of the device.

6.

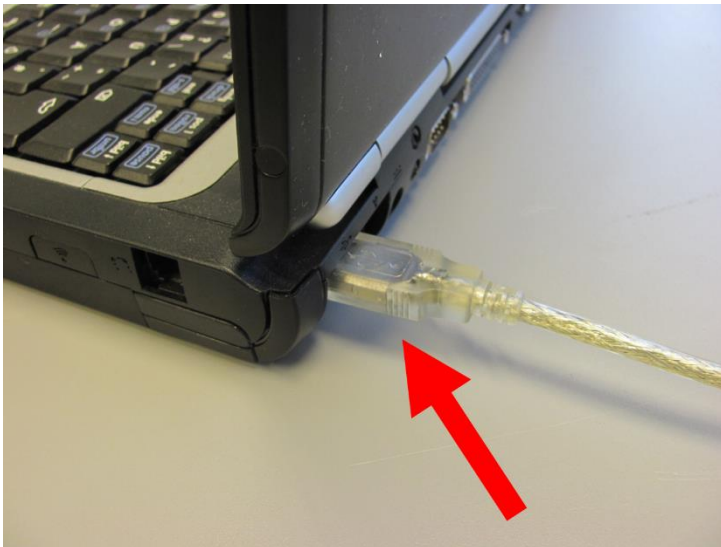

Prepare the connection of the other end of the USB cable to a computer, but don't plug it in yet

Caution: Assuming you go through a first-time installation it is necessary to first run the driver installation before connecting the IMS to the computer. This is in Analogy with installation of other external devices.

Ion-Mobility-Spectrometer User Manual

7a.



Connect one side of the remote cable to Port II connector at the rear of the Ion Mobility Spectrometer.

7b.

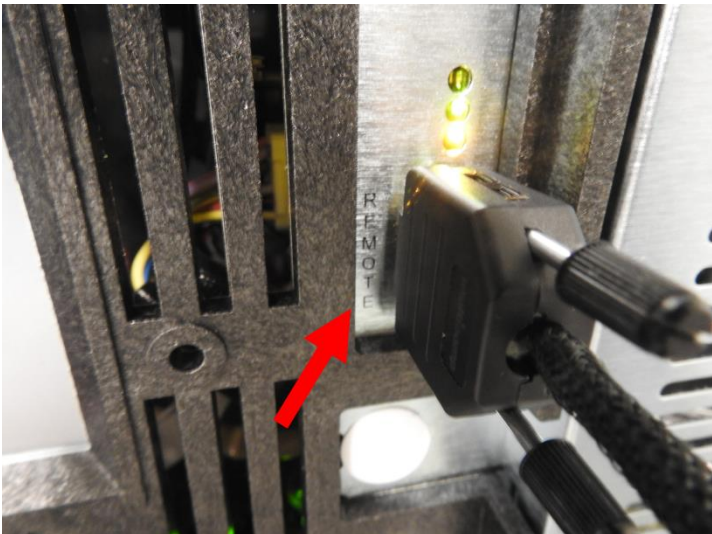

Connect the other side of the remote cable to Remote connector at the rear of the GC-System*.

**The picture shows the remote connector of an Agilent GC-System 7890B.*



6.3 Prepare Computer: Ion Mobility Spectrometer-Demonstration Software Installation



Information!

Before using the Ion Mobility Spectrometer for the first time the software must be installed.

Insert the provided USB-Memory stick into the PC slot and wait for the pop-up window as shown below. Select the file "GAS IMS Demo Kit.zip" and copy its content to your desktop and extract the content in an dedicated Folder

The demo software requires the *Microsoft Visual C++ 2010 Redistributable Package (x86)* as pre-requisite, you may need to install it before continuing. If you do not know if this package is installed on your computer, try to install it. The installer will tell if the package or a newer version is already installed.

1.

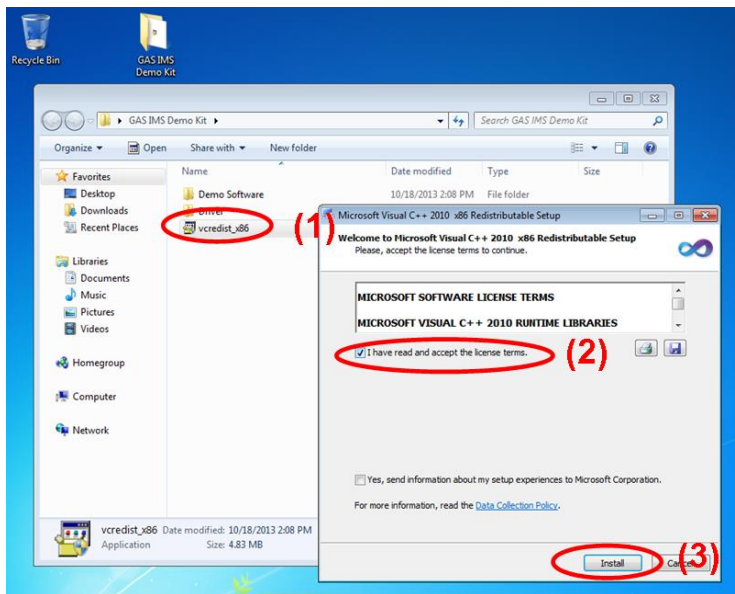

To install the *Microsoft Visual C++ 2010 Redistributable Package (x86)*, double click on **vcredist_x86 (1)**.

Accept the license terms **(2)** and click the 'Install' button **(3)**.

2.

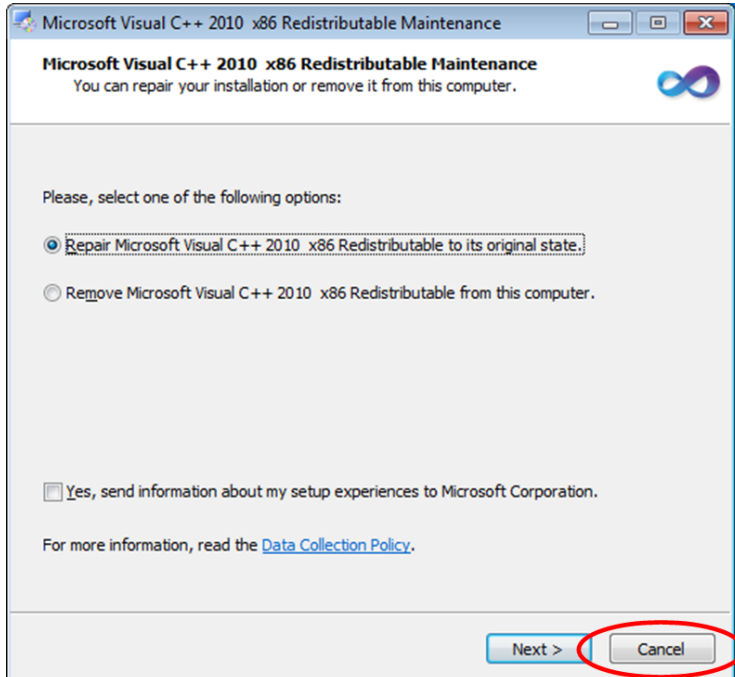

If the same version is already available on your computer, this dialog appears. Just select the 'Cancel' button.

Ion-Mobility-Spectrometer User Manual

3.

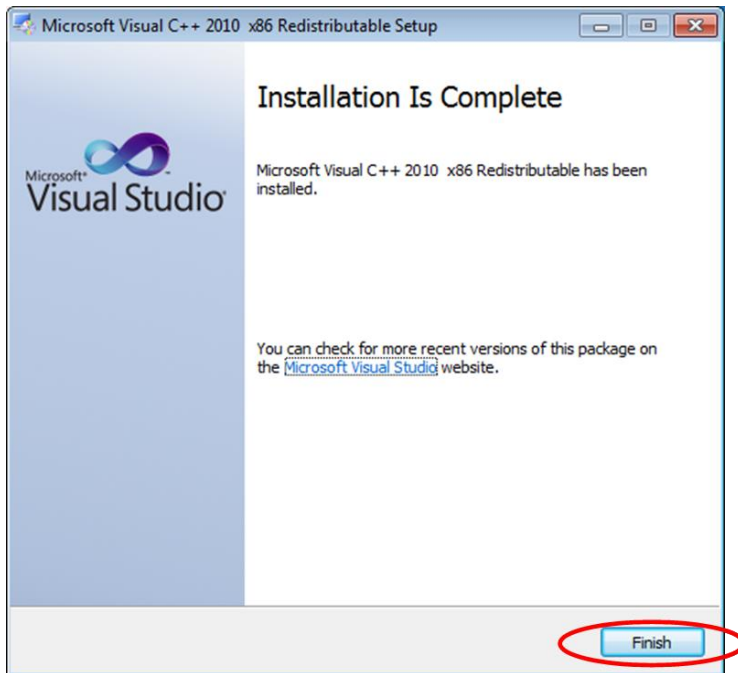

If there is no version of the *Microsoft Visual C++ 2010 Redistributable Package (x86)* on your computer, this dialog appears. Select the 'Finish' button to complete the installation procedure.

4.

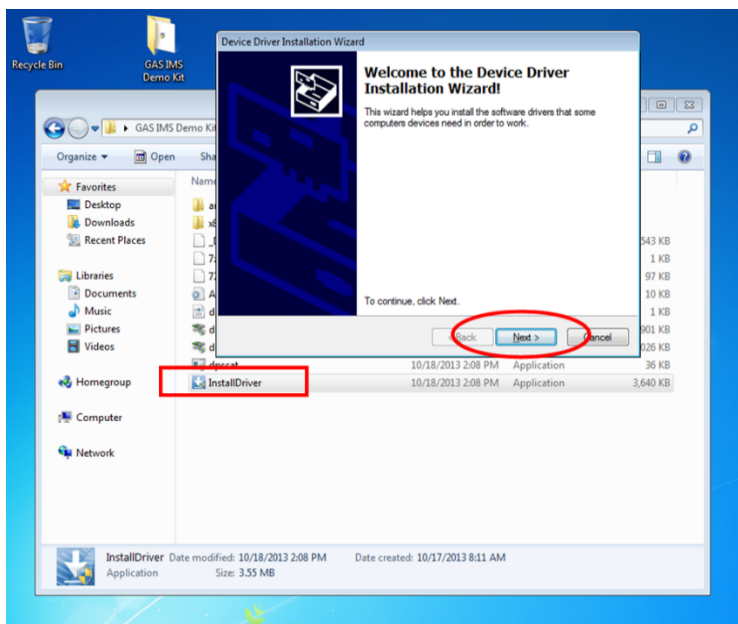

To install the driver for the IMS Module please open the Driver directory and double-click on 'InstallDriver.exe' and follow the on-screen instructions.

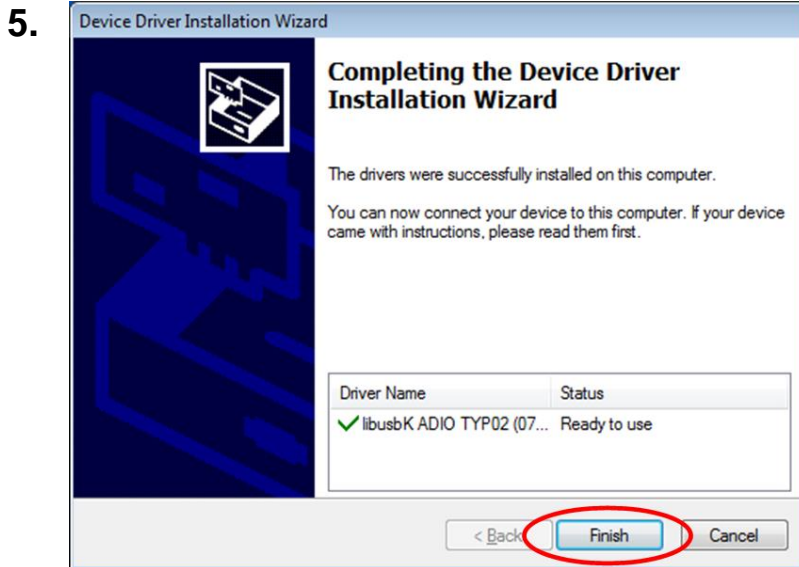

After a successful driver installation, select the 'Finish' button to complete the installation procedure.

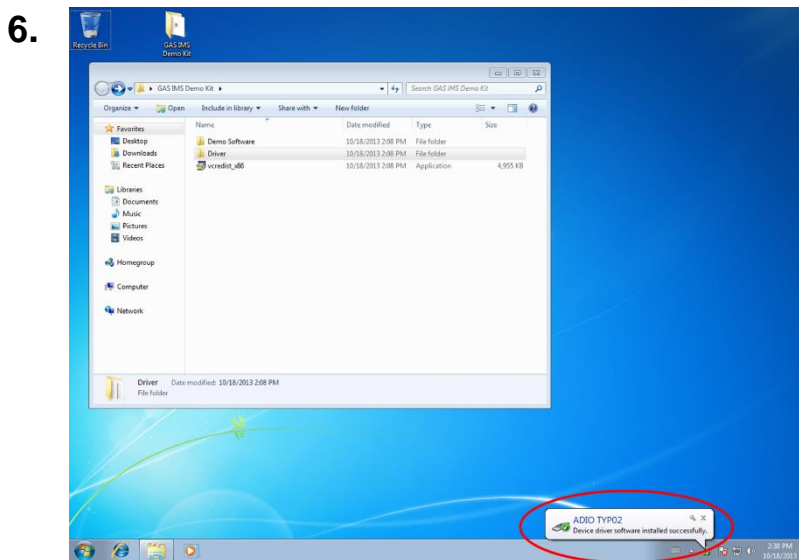

Once the driver is installed, connect the OEM Module's USB port to your computer using a standard USB 2.0 A to B cable. A message informing of the installation of the new hardware should appear.

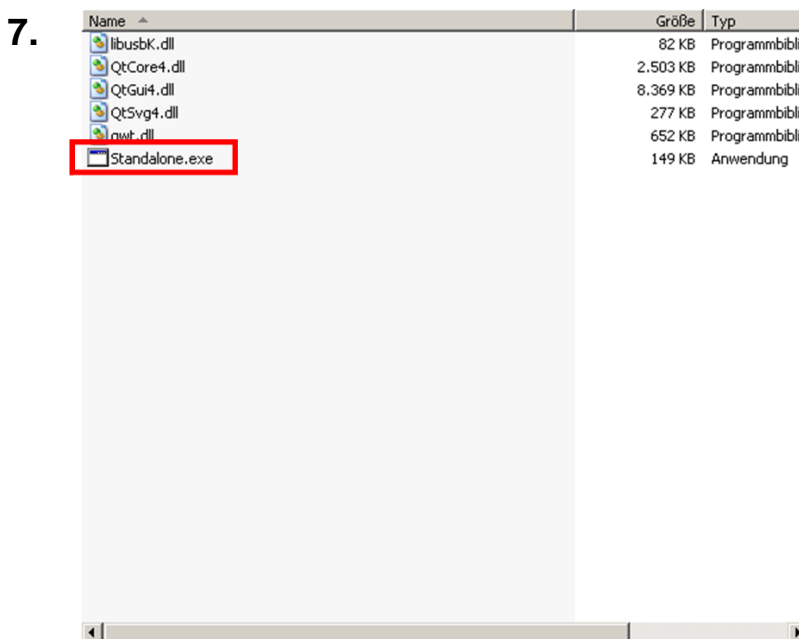

Open the folder "Demo Software" and double click the program 'Standalone.exe'. **This step only works after the hardware is completely installed (chapter 6.2).**

Ion-Mobility-Spectrometer User Manual

8.

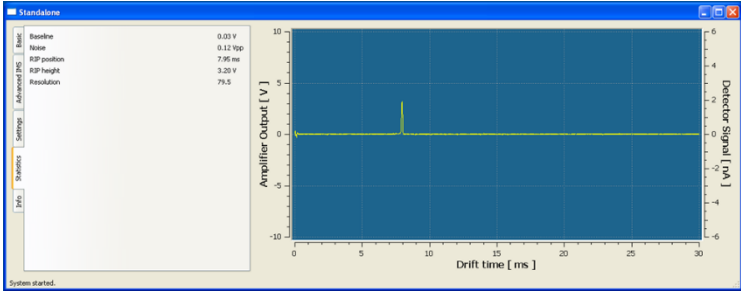

The standard screen of the software opens.

7 Ion Mobility Spectrometer Demonstration Software

7.1 Main Screen

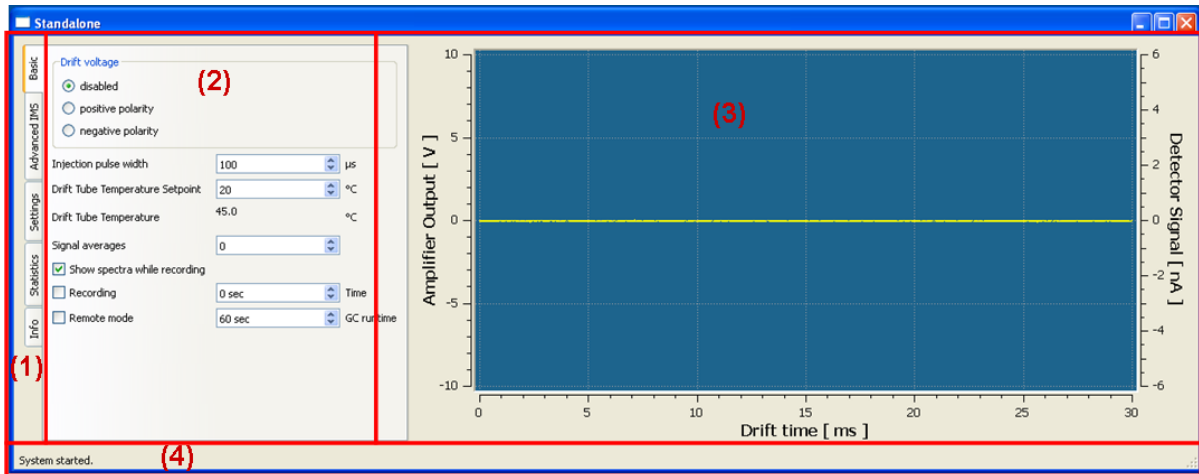

- (1) **Window selection bars** Allows the selection of the following sub-windows:
 - Basic (Standard window)
 - Advanced IMS
 - Settings
 - Statistics
 - Info
- (2) **Current settings / Information window** Displays the current setting / information window of the selected sub-window.
- (3) **Online monitoring window** Displays the current measurement
- (4) **Status bar** Displays status information

7.1.1 Basic Window

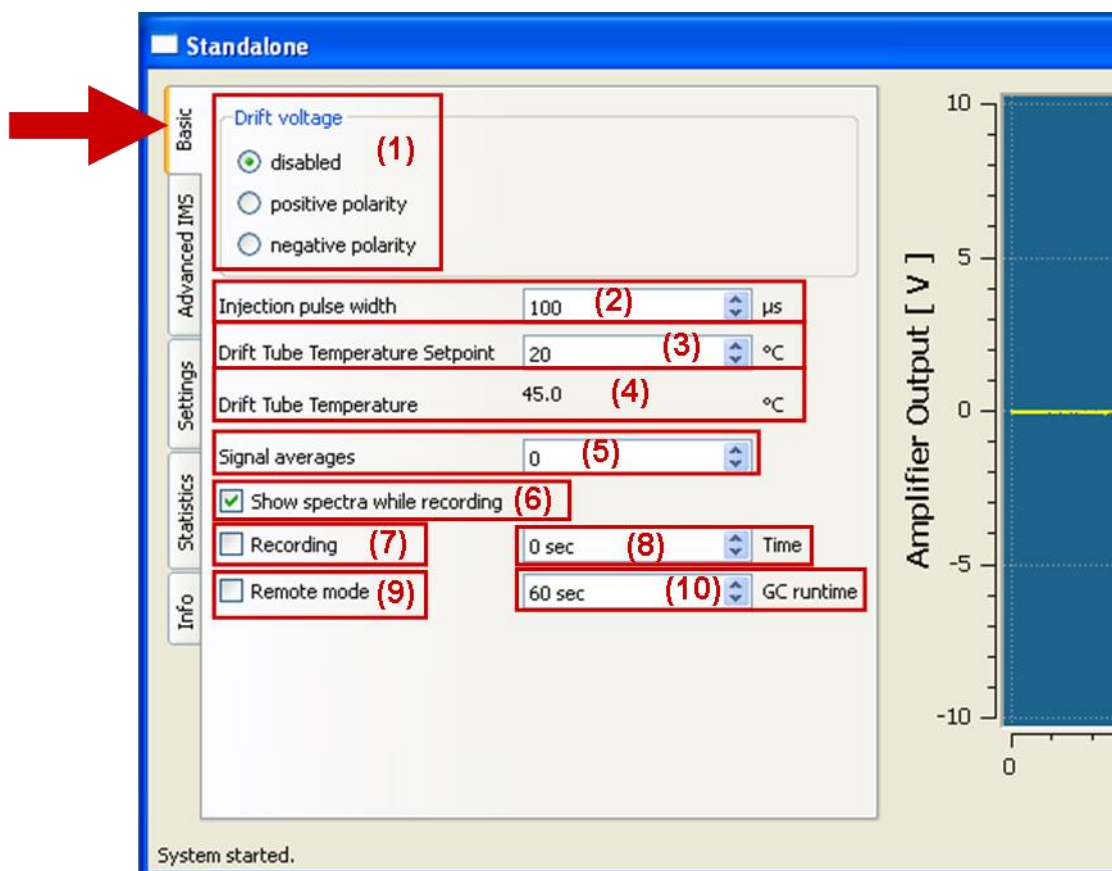

- | | |
|--|--|
| <p>(1) Drift voltage check boxes</p> | <p>The Drift voltage polarity can be set by using the checkboxes:</p> <ul style="list-style-type: none"> - disabled - positive polarity - negative polarity |
| <p>(2) Injection pulse width</p> | <p>The injection pulse width can be set. Values are given in microsecond (μs).</p> |
| <p>(3) Drift Tube Temperature Setpoint</p> | <p>The drift tube temperature can be set. Values are given in degree Celsius.</p> |
| <p>(4) Drift tube temperature</p> | <p>The present Drift Tube Temperature is displayed in degree Celsius.</p> |
| <p>(5) Signal averages</p> | <p>The number of averages can be set. The averaging value determines how many raw spectra are averaged to generate one single spectrum as result in the stored measurement file.</p> |
| <p>(6) Show spectra while recording check box</p> | <p>The monitoring of measurements can be activated.</p> |
| <p>(7) Recording check box</p> | <p>Enables the measurement recording. With this check box the live monitoring of measurements</p> |

can be recorded. By activating this check box, the recording starts immediately.

- (8) Recording time Set point** The duration of the measurement can be set. The unity is seconds.
- (9) Remote mode check box** Enables the measurement recording in remote mode. If a trigger signal is present the recording starts immediately by activating this check box.
- (10) Remote time Set point** The duration of the measurement in remote mode can be set. The unity is seconds.

7.1.2 Advanced IMS Window

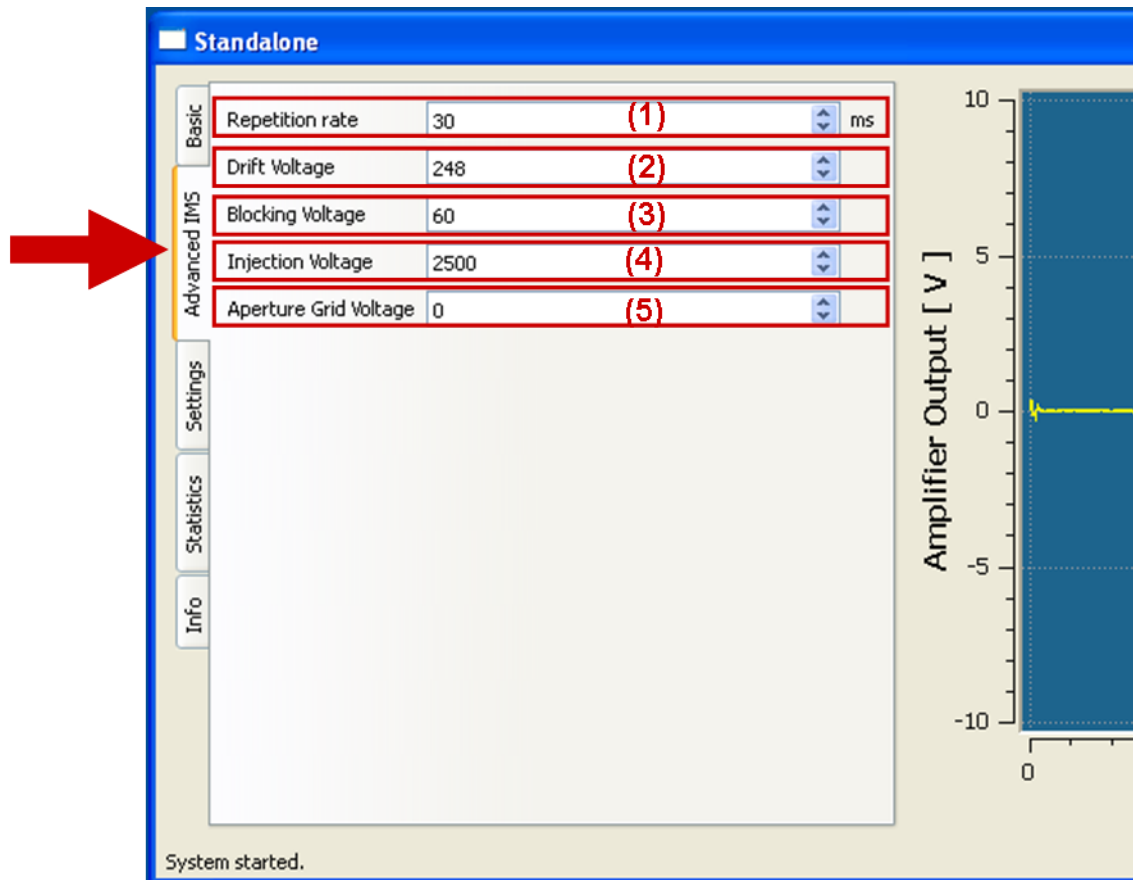

- (1) Repetition rate** Enables the repetition rate. The default value is 30 ms. This setting does not need to be changed.
- (2) Drift Voltage** The drift voltage can be set. The default value is sensor dependent and preset. This setting does not need to be changed by the user.
- (3) Blocking voltage** The blocking voltage can be set. The default value is sensor dependent and preset. This setting does not need to be changed by the user.
- (4) Injection voltage** The Injection voltage can be set. The default value is sensor dependent and preset. This setting does not normally need to be changed by the user.
- (5) Aperture Grid voltage** The Aperture Grid voltage can be set. The Aperture Grid voltage is not applied for the current IMS sensor generation. The default value is 0. This setting does not need to be changed by the user.

7.1.3 Settings Window

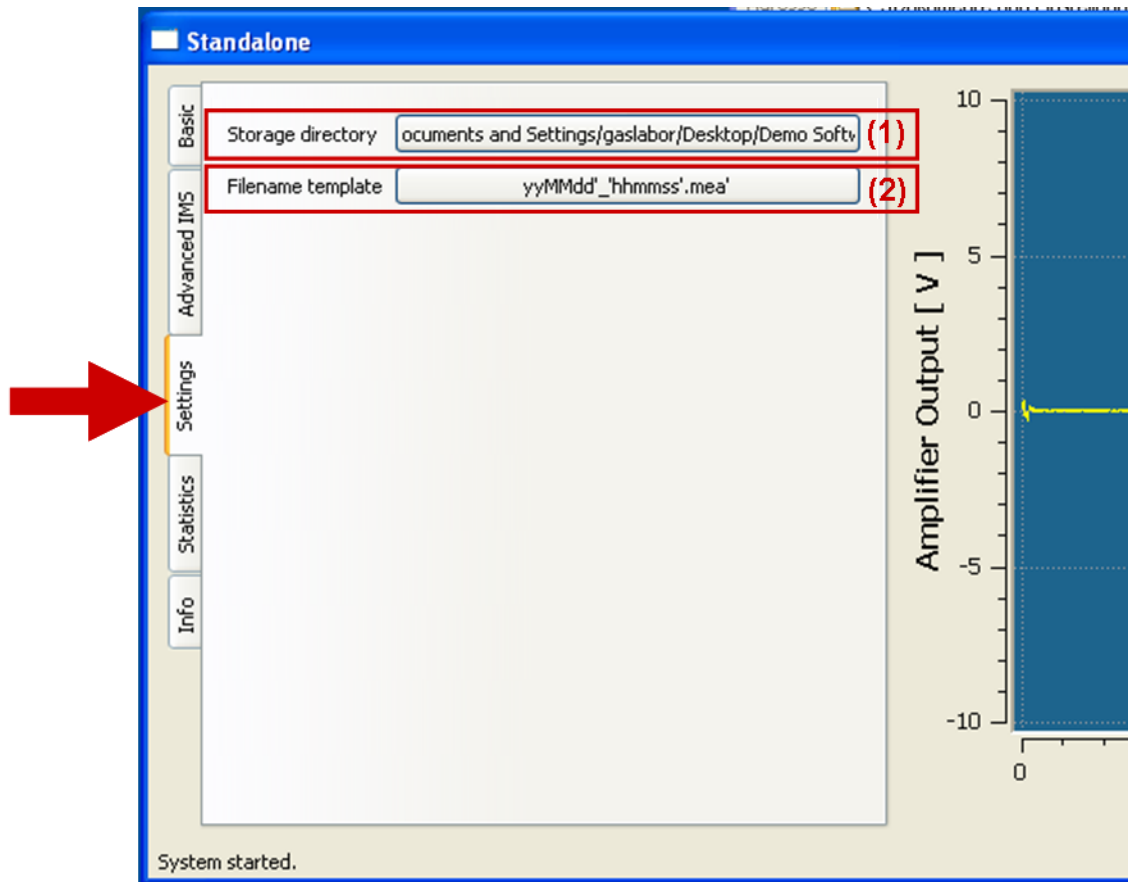

- (1) **Storage directory** An individually storage directory and folder can be chosen.
- (2) **Filename template** An individually filename template can be chosen.

Ion-Mobility-Spectrometer User Manual

7.1.3.1 Storage directory window

By selecting the Storage directory button the following window will be displayed. An individually storage directory can be chosen.



7.1.3.2 Filename template window

By selecting the Filename template button the following window will be displayed.



The default Filename template is yyMMdd'_'hhmmss'.mea'

The default Filename template can be edited. The characters written between apostrophes ('...') are taken over. All characters can be used that are allowed by the windows operating system. The following table shows the valid values that are evaluated by the system:

Value	Description
%SAMPLE%	the Sample number
d	the day as number without a leading zero (1 to 31)
dd	the day as number with a leading zero (01 to 31)
ddd	the abbreviated localized day name (e.g. 'Mon' to 'Sun').
dddd	the long localized day name (e.g. 'Monday' to 'Sunday').

Ion-Mobility-Spectrometer User Manual

M	the month as number without a leading zero (1-12)
MM	the month as number with a leading zero (01-12)
MMM	the abbreviated localized month name (e.g. 'Jan' to 'Dec').
MMMM	the long localized month name (e.g. 'January' to 'December').
yy	the year as two digit number (00-99)
yyyy	the year as four digit number
h	the hour without a leading zero (0 to 23 or 1 to 12 if AM/PM display)
hh	the hour with a leading zero (00 to 23 or 01 to 12 if AM/PM display)
H	the hour without a leading zero (0 to 23, even with AM/PM display)
HH	the hour with a leading zero (00 to 23, even with AM/PM display)
m	the minute without a leading zero (0 to 59)
mm	the minute with a leading zero (00 to 59)
s	the second without a leading zero (0 to 59)
ss	the second with a leading zero (00 to 59)
z	the milliseconds without leading zeroes (0 to 999)
zzz	the milliseconds with leading zeroes (000 to 999)
AP or A	interpret as an AM/PM time. AP must be either "AM" or "PM".

7.1.3.3 Statistics Window

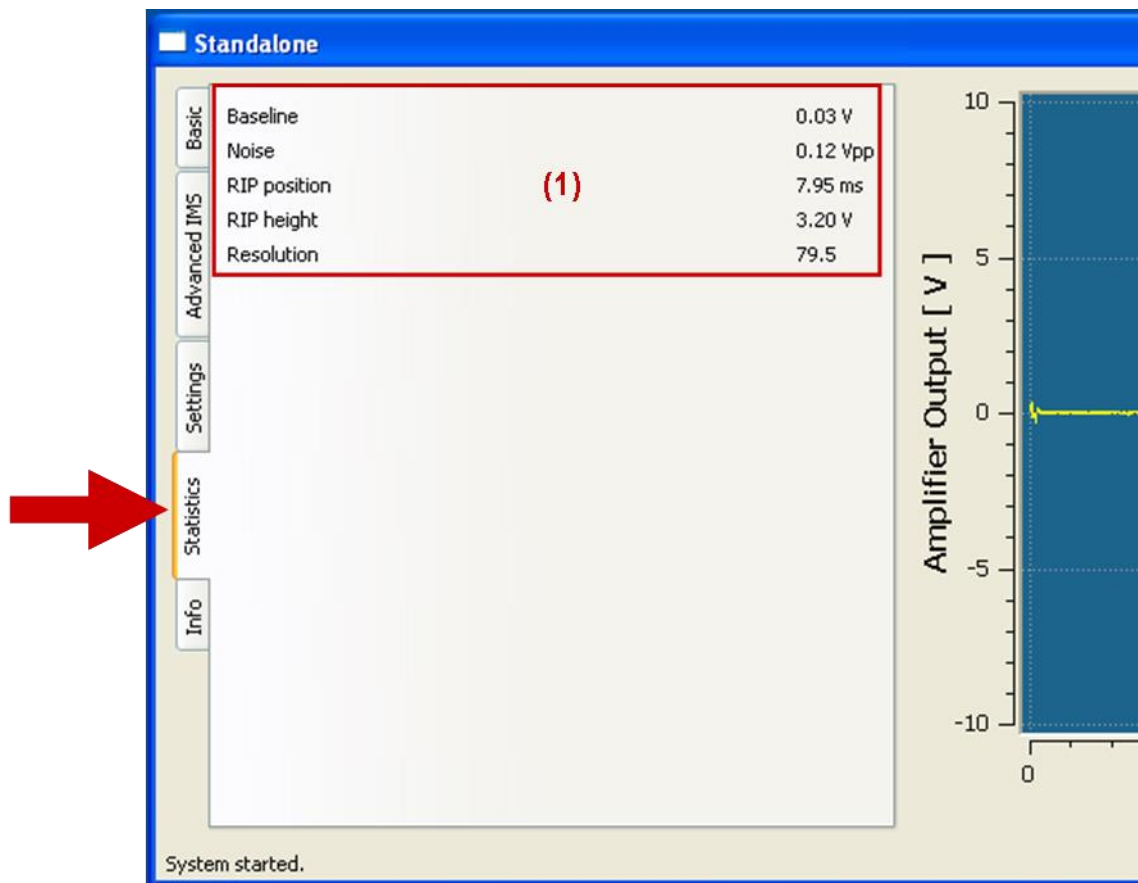

(1) Statistics window

Different values of the actual measurement are displayed. At the moment the following values are displayed:

- Baseline
- Noise
- RIP Position
- RIP Height
- Resolution

7.1.4 Info Window

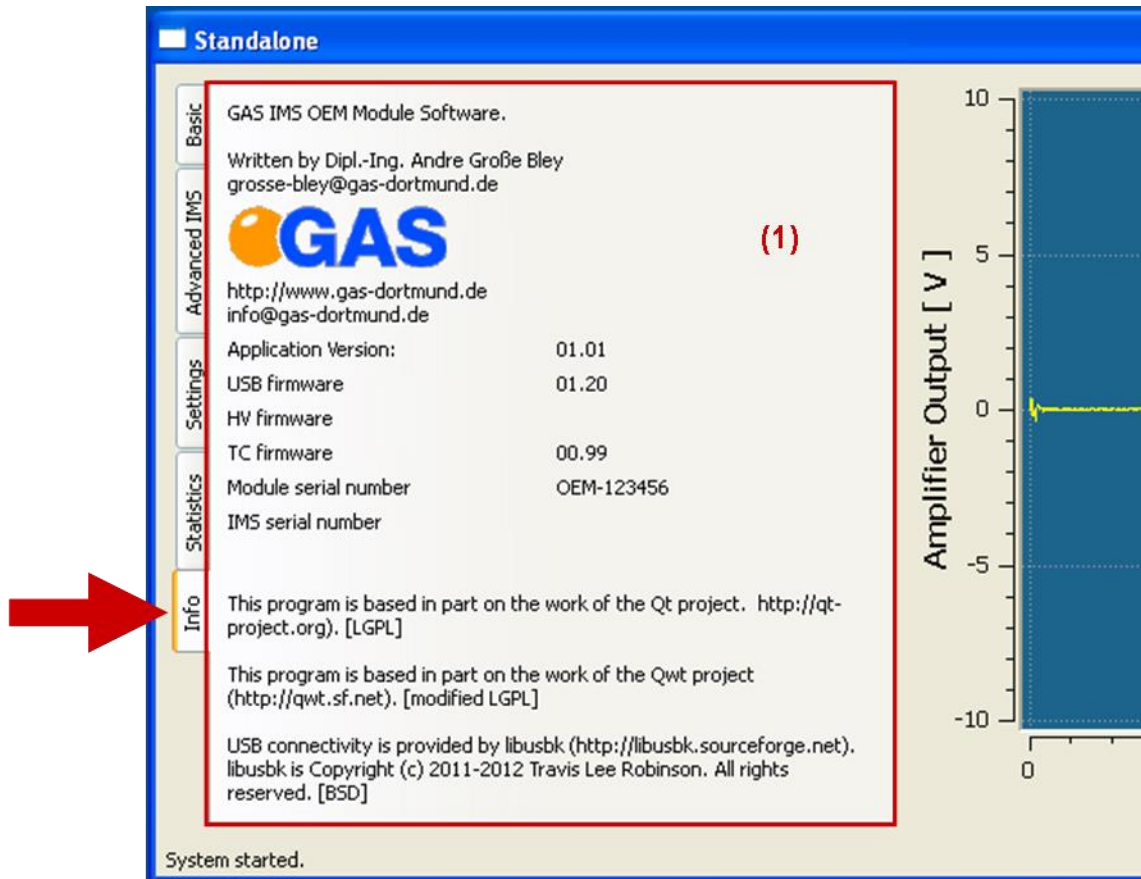

(1) Info window Shows general Software and hardware information

7.1.5 Monitoring window

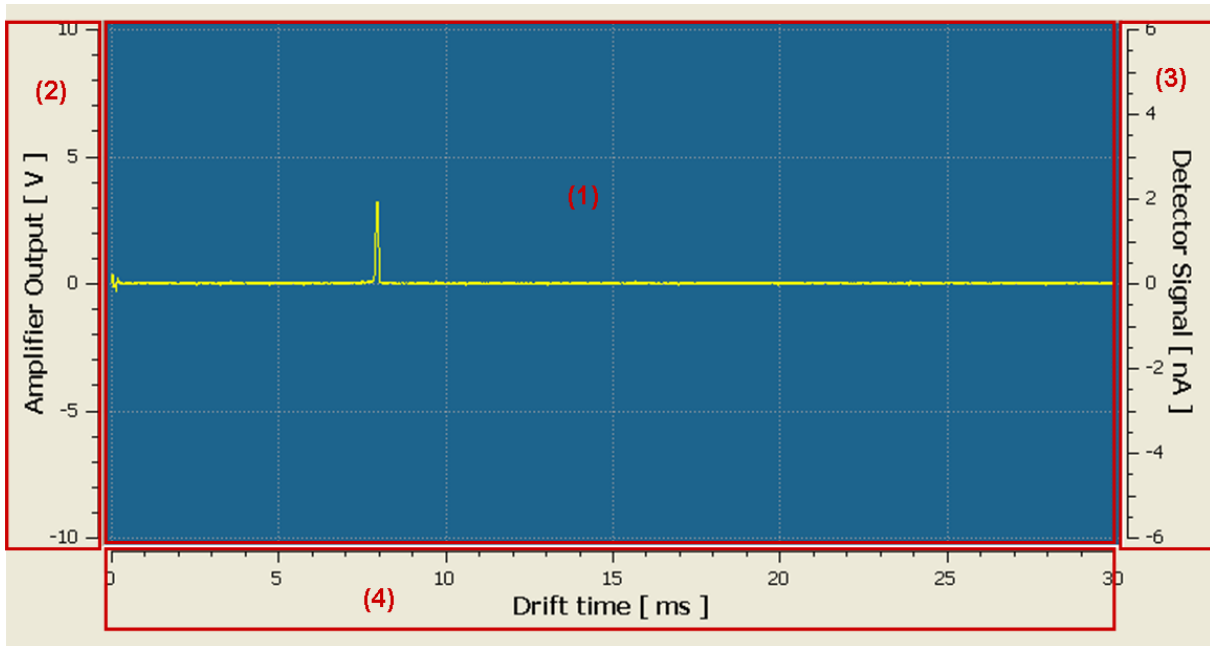

By selecting the `Show spectra while recording` check box in the Basic Window the monitoring of the actual detector signal is shown in Single IMS Spectrum View.

- | | |
|------------------|--------------------------------|
| (1) Screen | Single IMS Spectrum View |
| (2) Y-axis left | Signal intensity in volt |
| (3) Y-axis right | Signal intensity in nanoampere |
| (4) X-axis | Drift time in milliseconds |

7.1.6 Zooming

1.

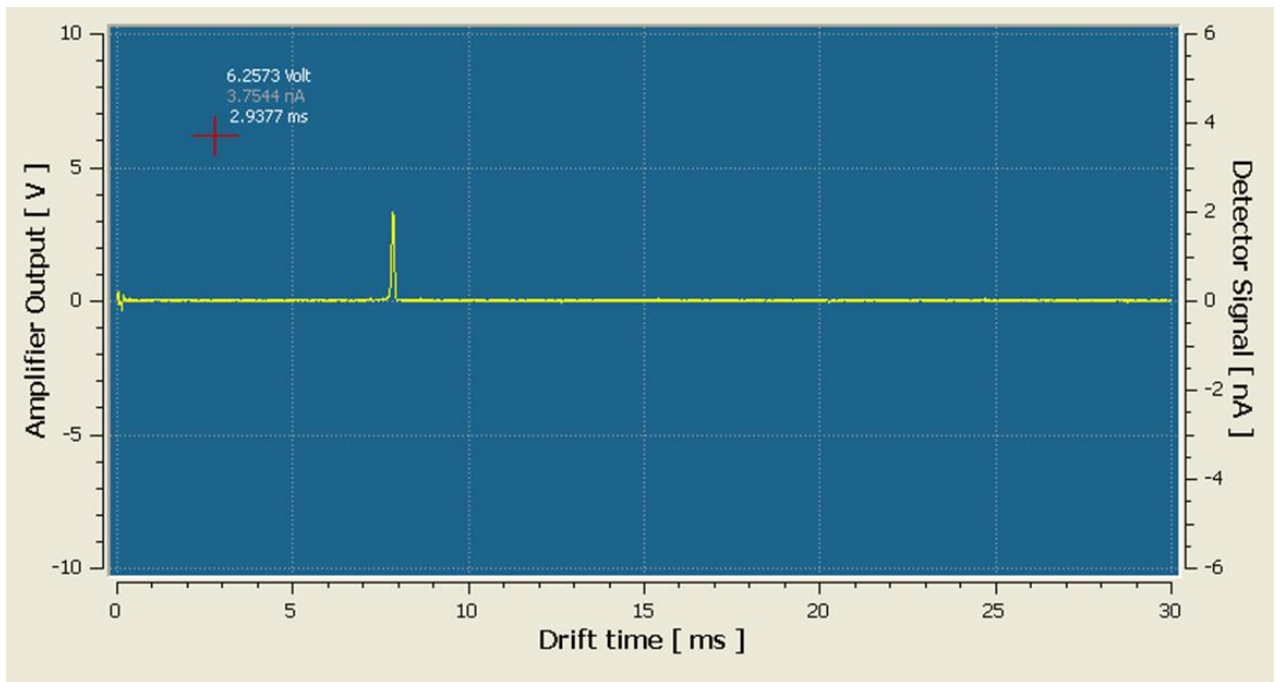

Move the mouse into the screen. The mouse cursor will be displayed as cross line.

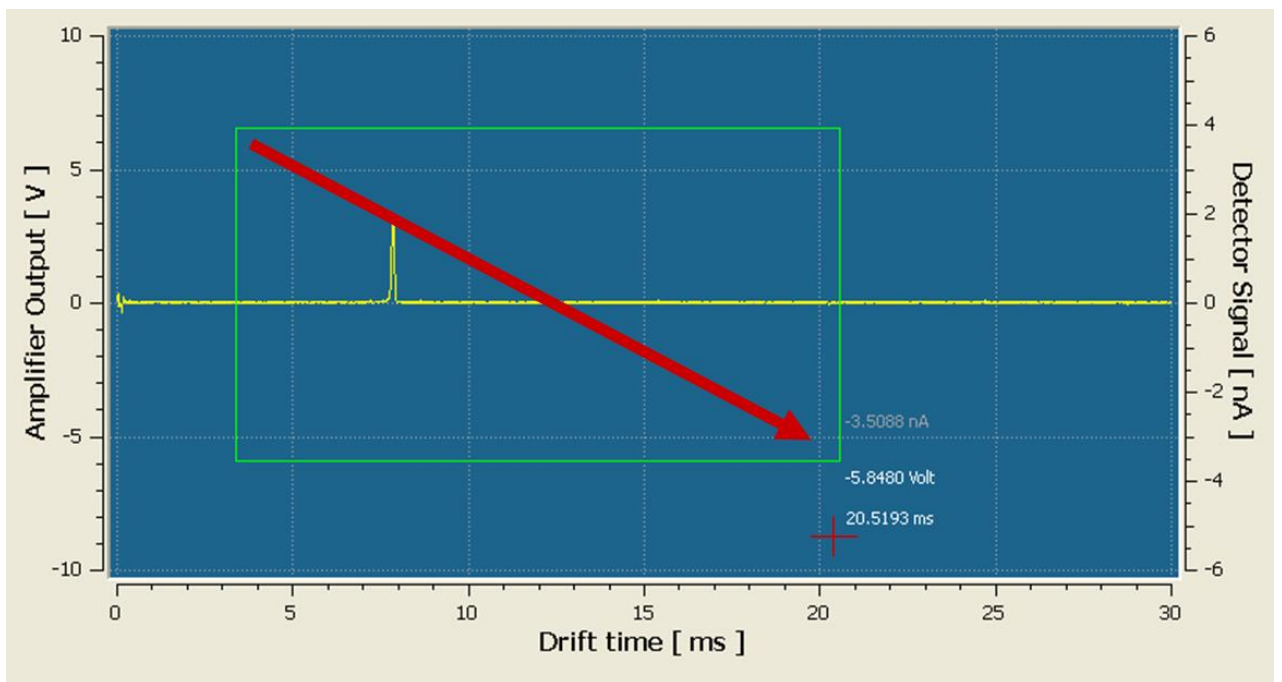

2.

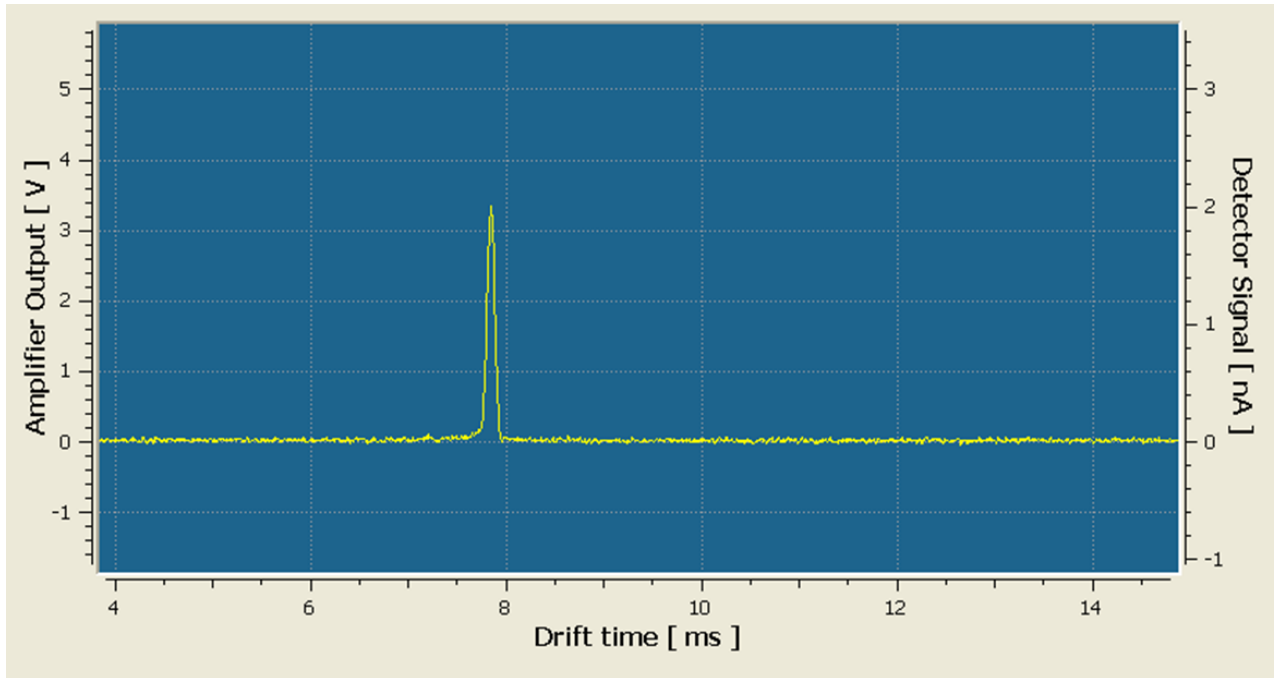

Click with the left mouse button into the screen and keep the left mouse button pushed. Drag your mouse from top left to bottom right. The selection bar is outlined in green.

3.



Releasing the left mouse button  the view is zoomed into the selection bar. To minimize the view move the mouse into the screen and click the right mouse button . The view return to the previous view. By repeated clicking the right mouse button  you can go backwards step by step.

8 System Operation

8.1 Start operating the Ion Mobility Spectrometer

As a first step the device has to be cleaned to reach proper condition. The cleaning period is depending on how long the device was switched off. Install the device, (Chapter 6.3) and set the **working input pressure of the driftgas to 3 bar** , to assure a constant gasflow of about 150 ml/min $\pm 10\%$. Install the Ion Mobility Spectrometer Demonstration Software (Chapter 6.1) and setup the **Drift tube temperature to 100 °C** (Chapter 8.4).

After **18 hours** of cleaning the RIP in the positive drift voltage mode should reach **~80% of the RIP-Height** displayed in the delivered **Analytical Approval** under additional conditions.

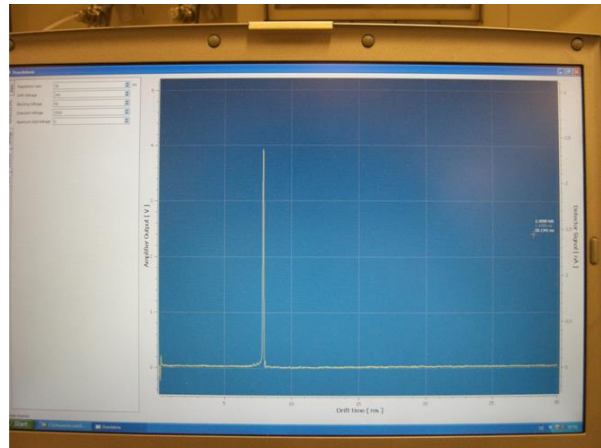
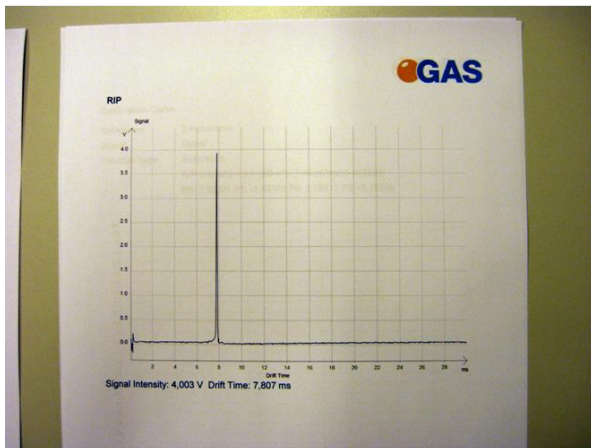

If this is not the case check the quality of your gas and/or install additional purification cartridges and start the cleaning procedure again



Information!

This information are based on the assumption that the device has not been switched off longer than 14 days.



Information!

Only use stainless steel pressure reducer, PTFE tubes with 3 mm outer diameter and 3 mm swagelok connectors.

Ensure that you use at least **Nitrogen 5.0** .

Ion-Mobility-Spectrometer User Manual

To ensure a high purity of the gas install the provided moisture trap.

8.2 Measurement default values

The following table shows possible and useful values to run a measurement. All values are adaptable and can be changed. Certain values like the drift time voltage are sensor specific and should therefore not be changed. Other values like the recording time should be adjusted to individual needs (see table below).

Parameter	positive Polarity	negative Polarity
Injection pulse width (μ s)	150*	150*
Drift tube temperature (°C)	45**	45**
Signal averages	12**	12**
Recording time (sec)	60**	60**
Repetition rate (ms)	30*	30*
Drift voltage	246*	-248*
Blocking voltage	50*	2000*
Injection voltage	2500*	-10*
Aperture grid voltage	0*	0*

* individual default value (usually need not be changed)
** example value (should be adjusted to individual needs)

8.3 Possible value range

All parameters of the Ion Mobility Spectrometer can be set in the Ion Mobility Spectrometer Demonstration Software. The following table shows the possible value range.

Parameter	Value range
Injection pulse width (μ s)	0 - 2000
Drift tube temperature (°C)	20 - 100
Signal averages	0 - 127
Recording time (sec)	0 - 86400
Repetition rate (ms)	2- 200
Drift voltage	(-255) - 255
Blocking voltage	(-255) - 255
Injection voltage	0 - 4095

Aperture grid voltage	(-1023) - 1023
-----------------------	----------------



Information!

Note that wrong values could damage the sensor. Be careful when setting these. In case of doubts, please contact the G.A.S. hotline.

8.4 General IMS Parameter settings

1.

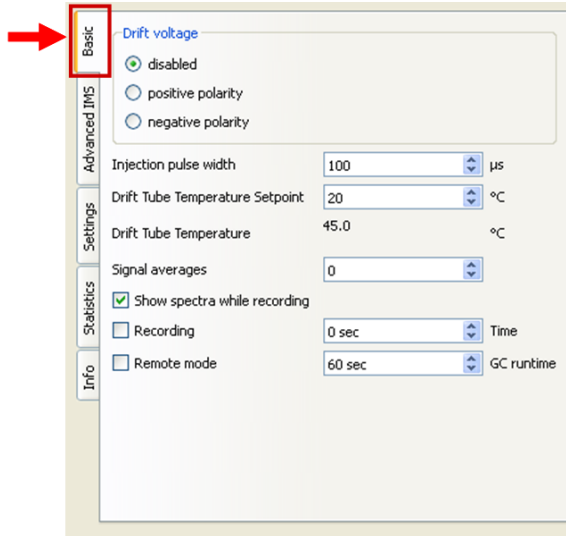

Select the Basic Window

2.

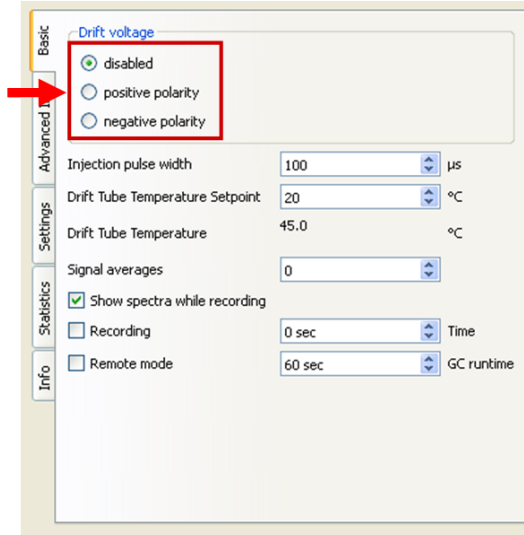

Activate the Drift voltage polarity

Ion-Mobility-Spectrometer User Manual

3.

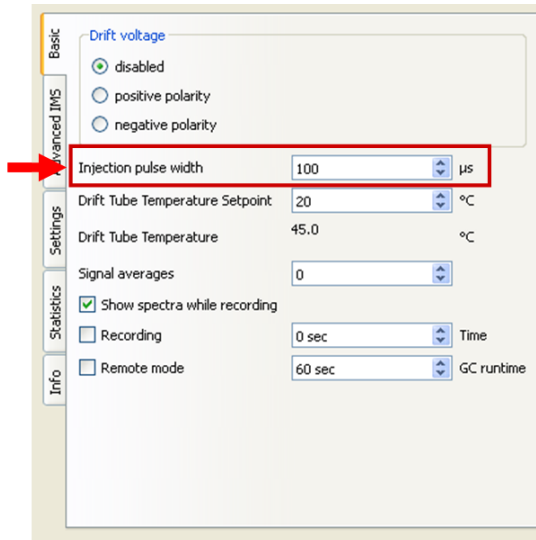

Setting of the Injection pulse width. The default value is 100 μs.

4.

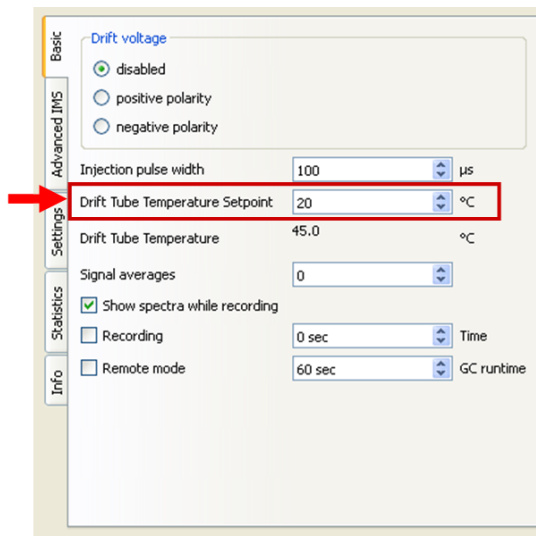

Setting of the drift tube temperature. The default value is 20 °C. Typical settings are 45 °C depending on the application.

5.

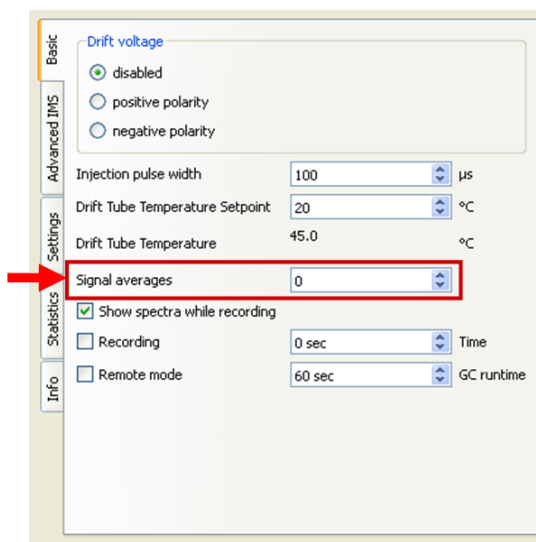

Setting of the 'Signal averages'. The default value is 0. Typical settings are 6 or 12.

6.

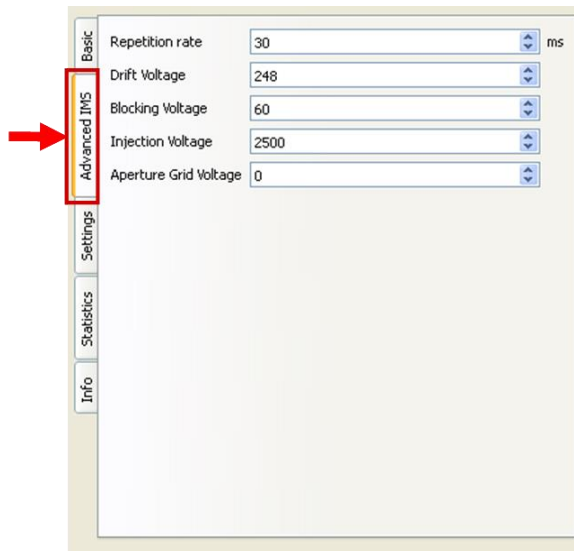

Select the 'Advanced IMS' Window

7.

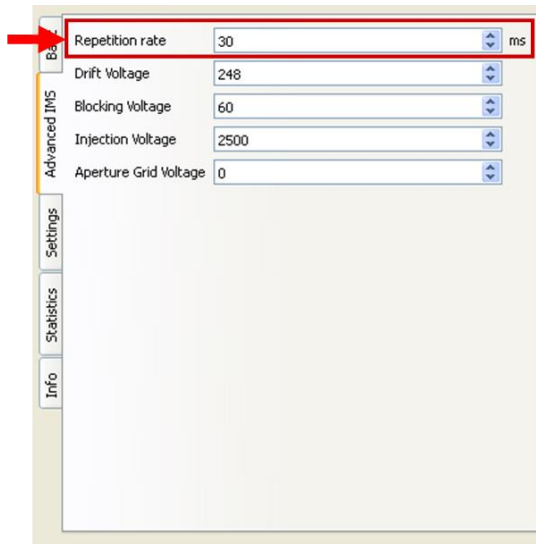

Setting of the 'Repetition rate'. The default value is 30 ms. This setting does not normally need to be changed.

8.

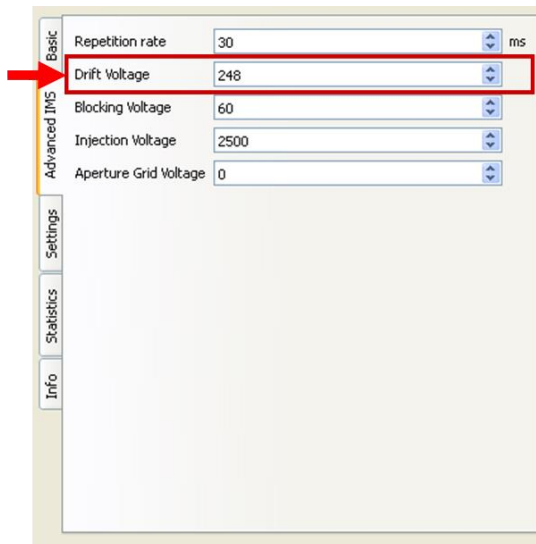

Setting of the 'Drift voltage'. The default value varies between sensors and is and has been uploaded as factory default value. This setting does not need to be changed.

Ion-Mobility-Spectrometer User Manual

9.

The screenshot shows a settings window with a sidebar on the left containing buttons for 'Basic', 'Advanced IMS', 'Settings', 'Statistics', and 'Info'. The 'Basic' tab is selected. The main area contains five settings, each with a text input field and a dropdown arrow on the right. The 'Blocking Voltage' field is highlighted with a red box, and a red arrow points to it from the left. The other settings are: Repetition rate (30 ms), Drift Voltage (248), Injection Voltage (2500), and Aperture Grid Voltage (0).

Repetition rate	30	ms
Drift Voltage	248	
Blocking Voltage	60	
Injection Voltage	2500	
Aperture Grid Voltage	0	

Setting of the 'Blocking Voltage'. The default varies between sensors and is and has been uploaded as factory default value preset. This setting does not need to be changed.

10.

The screenshot shows the same settings window as in step 9. The 'Advanced IMS' tab is selected in the sidebar. The 'Injection Voltage' field is highlighted with a red box, and a red arrow points to it from the left. The other settings are: Repetition rate (30 ms), Drift Voltage (248), Blocking Voltage (60), and Aperture Grid Voltage (0).

Repetition rate	30	ms
Drift Voltage	248	
Blocking Voltage	60	
Injection Voltage	2500	
Aperture Grid Voltage	0	

Setting of the 'Injection voltage. The default value varies between sensors and is and has been uploaded as factory default value preset. This setting does not need to be changed.

11.

The screenshot shows the same settings window as in step 9. The 'Advanced IMS' tab is selected in the sidebar. The 'Aperture Grid Voltage' field is highlighted with a red box, and a red arrow points to it from the left. The other settings are: Repetition rate (30 ms), Drift Voltage (248), Blocking Voltage (60), and Injection Voltage (2500).

Repetition rate	30	ms
Drift Voltage	248	
Blocking Voltage	60	
Injection Voltage	2500	
Aperture Grid Voltage	0	

The Aperture Grid voltage can be set by the user. However the Aperture Grid voltage setting is not necessary for the current IMS sensor generation. The default value is 0. This setting does not need to be changed.

8.5 Recording a measurement

1.

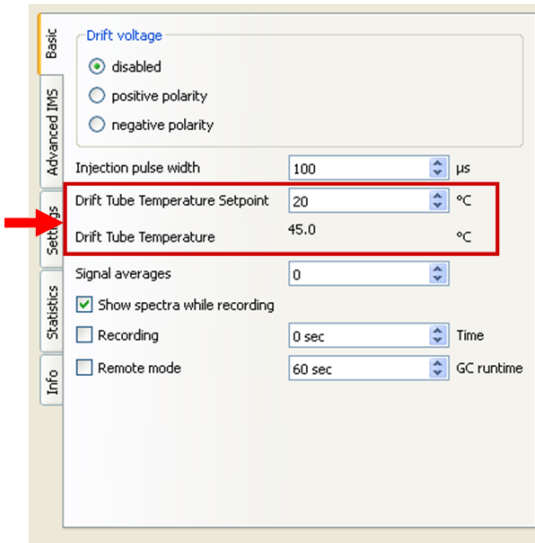

Check the Drift Tube Temperature

2.

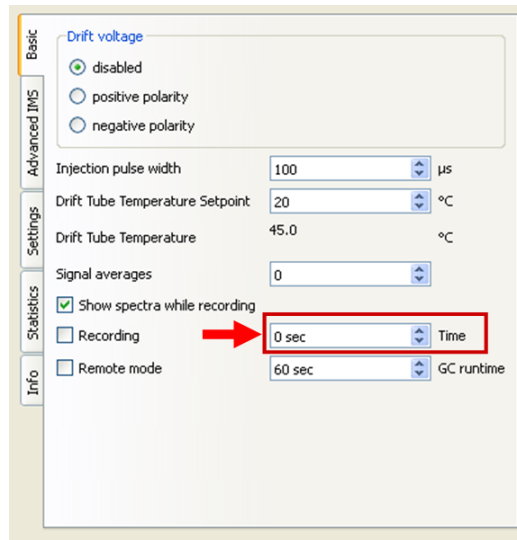

Set the measurement time in sec.

3.

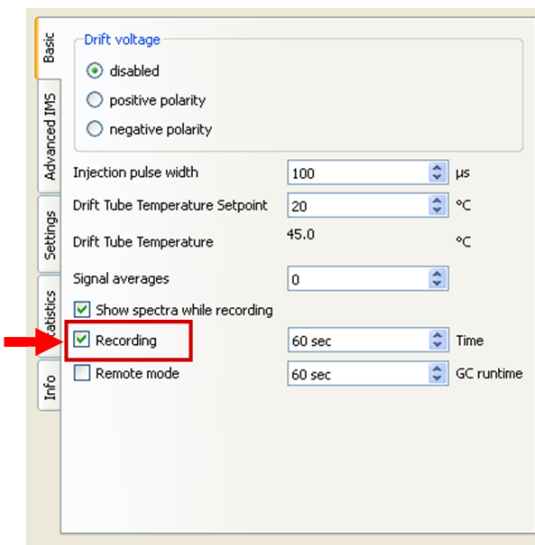

Enable the 'Recording' Button

8.6 Remote mode recording



Information!

It is preconditioned that the Ion Mobility Spectrometer is properly connected to a device that is able to send a external trigger signal to start the recording.

1.

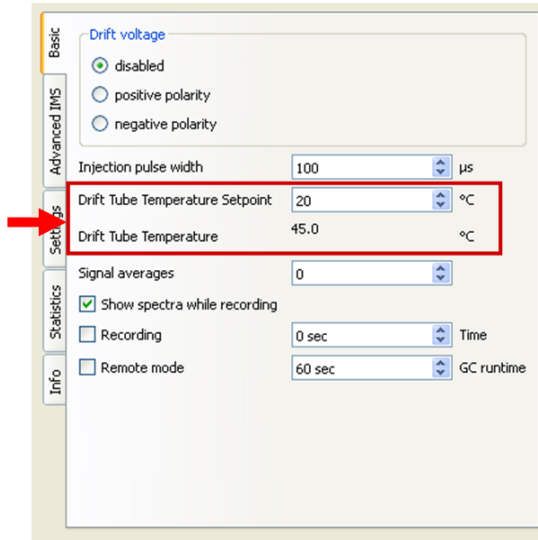

Check the Drift Tube Temperature

2.

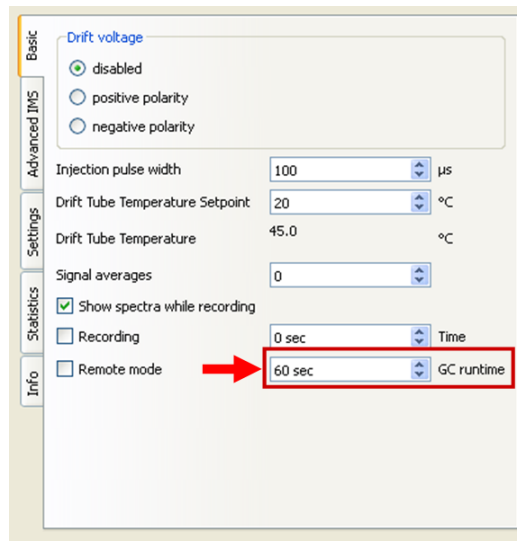

Set the GC runtime time in sec.

3.

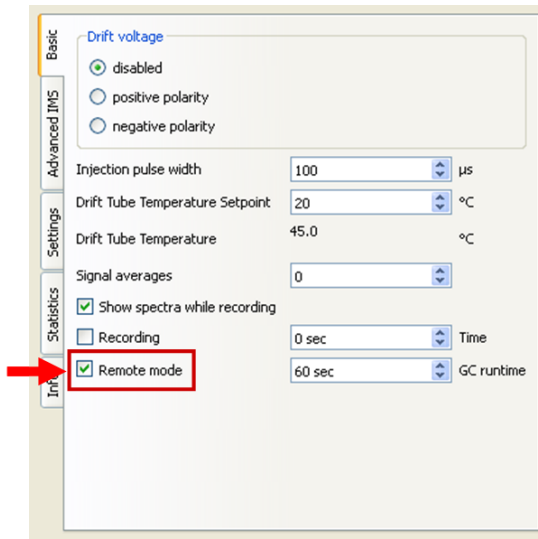

Enable the 'Remote mode' button. As soon as a external trigger signal is available the recoding starts.

9 Exemplary workflow

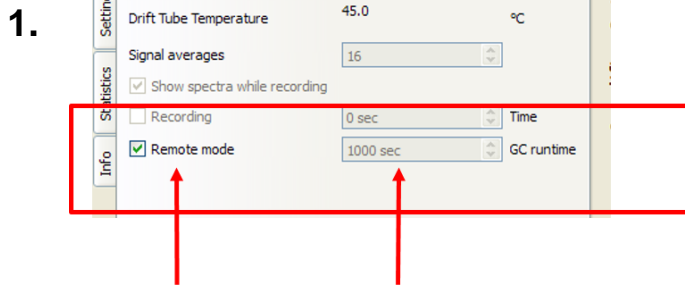

In Standalone software:

Activate Remote mode and enter the GC runtime in seconds (corresponds with the runtime of the GC methode).



Information!

The working input pressure of the driftgas must be set to 3 bar, to assure a constant gasflow of about 150 ml/min \pm 10%

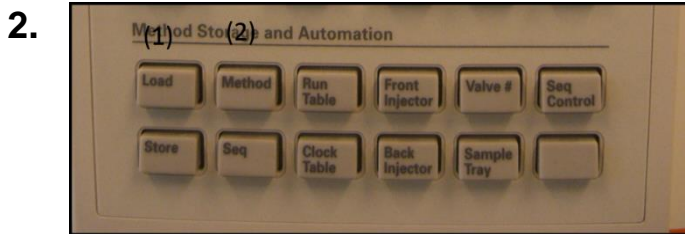

On GC-System:

- (1) Press Load to select a methode
- (2) Press Methode



Select Methode number and press ENTER

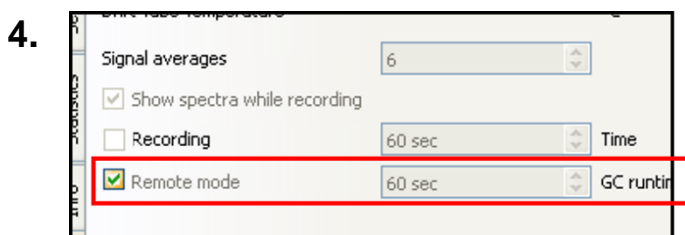

In Ion Mobility Spectrometer software:

Activate Remote mode and enter the GC runtime in seconds (corresponds with the runtime of the GC methode).

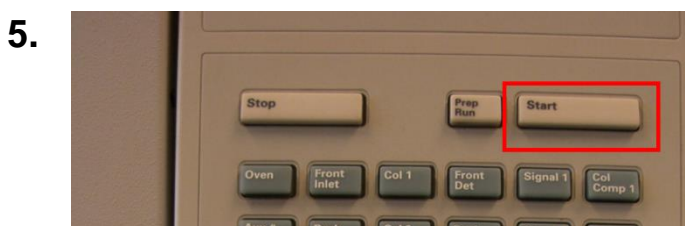

Select Start to start the measurement

Ion-Mobility-Spectrometer User Manual

6.



Inject sample

10 Technical data

Electrical

DC Input	24V DC +-10%, 12 W (unheated IMS) 30 W (heated IMS)
Signal output	Analog conditioned sensor Signal (Range +-10 V) TTL Trigger Output for synchronisation or USB 2.0 High Speed digital interface 14 bit, 150 kS/s Bulk data stream (up to 400 kS/s optional)
Control interface	USB 2.0, 2 Interrupt endpoints APG-Like Interface for interoperation with a GC or synchronization to external sampling system (RS232 optional) (TTL compatible inputs for mode selection optional)
Temperature controller (optional)	2 Channel PI Controller for PT100 up to 100°C +-0.1 K accuracy +-1 K display accuracy

Gas connections

Gas In	3 mm or 1/8" Swagelok (Other connectors available on request)
Gas out	3 mm or 1/8" Swagelok (Other connectors available on request)
Sample In	Heated transferline GC-System side

Gas supply

Gas (purity level)	nitrogen (5.0) or synthetic air (5.0)
--------------------	---------------------------------------

Dimension

Housing	Height: 300 mm Width: 140 mm Depth: 482 mm
---------	--

Ion Mobility Sensor

Radiation source	^3H (β^- emission) bound in metal < 500 MBq,
Licence	No licence in all EURATOM member states needed <i>(Below Exemption limit of 1 GBq for tritium acc. to Annex I, Table A of article 3, 2 (a) of the Directive 96/26 EURATOM of May 13, 1996)</i>
Lifetime	12.5 years half-life
Drift tube material	Stainless steel and PEEK

Ion-Mobility-Spectrometer User Manual

Drift tube inner diameter	15.2 mm
Drift tube length	98 mm
Drift field strength	500 V/cm
Drift voltage polarity	positive and negative, switchable during operation
Amplifier impedance	3 V/nA
Electric Heating of IMS	up to 100°C (optional)
IMS analytical resolution	> 55 (positive RIP, 20°C)
Spectra rate	every 30 ms

GAS IMS OEM Module Demonstration Software

System requirements	Windows XP with Service Pack 3 or Windows 7 (32 or 64 bit) or Windows 8 (32 or 64 bit) or 1 High Speed USB2.0 port
Data storage	Data storage in "mea" format suitable for post processing with G.A.S. LAV software suite.
Licences	This software is based in part on the work of the Qt project, http://www.qt-project.org licensed under LGPL2.1. The license is included in verbatim in the Archive containing the software. This software is based in part on the work of the Qwt project, http://qwt.sf.net , licensed under a modified LGPL. The license is included in verbatim in the Archive containing the software. USB connectivity is provided by libusbK, http://libusbk.sourceforge.net/UsbK3/index.html , licensed under BSD license included in verbatim in the archive containing the software.

External Connectors

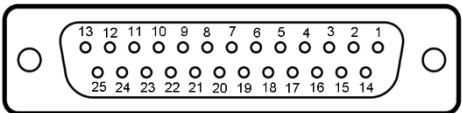
Port I (<i>reserved for future options</i>)	
	
25 Pin Sub-D female connector	
Pin	Signal Name
1	reserved

2	reserved
3	reserved
4	reserved
5	reserved
6	reserved
7	reserved
8	reserved
9	reserved
10	reserved
11	reserved
12	reserved
13	reserved
14	reserved
15	reserved
16	reserved
17	reserved
18	reserved
19	reserved
20	reserved
21	reserved
22	reserved
23	reserved
24	reserved
25	reserved

Connector Port II

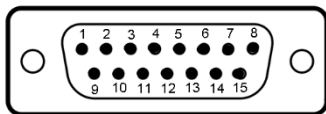

15 Pin Sub-D male connector

Pin	Signal Name
1	reserved
2	reserved
3	IMS Signal Frameset (output)
4	Signal Ground
5	Pullup (4,7 kOhm to +5V)
6	#START (input)
7	GPIO1
8	-
9	reserved
10	reserved
11	Analog IMS Signal (output)
12	Signal Ground
13	Pullup
14	GPIO0
15	GPIO2

#START, GPIO0, GPIO1, GPIO2 are internally pulled up (100kOhm) to +5V

Do not apply voltages in excess of 5V to any Ion Mobility Spectrometer signal. GPIO/#START are 5V tolerant CMOS inputs. Exceeding these ratings will damage the Ion Mobility Spectrometer main board.

Optionally (need to be specified on order) Pin 1,2,9,10 can be used as DC Input to reduce external cabling to the GAS Ion Mobility Spectrometer or can provide an auxiliary temperature controller.

Ion-Mobility-Spectrometer User Manual

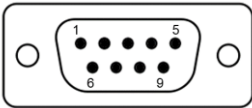

9-pin Sub-male connector

Pin	Signal Name
1	Common (-)
2	Supply 0 Vdc
3	Supply +24Vdc
4	Output (+)
5	Setpoint (+)
6	Tx+ RS485
7	Tx- RS485
8	Rx- RS485
9	Rx+ RS485